

RESEARCH ARTICLE

No response to linear polarization cues in operant conditioning experiments with zebra finches

Julian Melgar¹, Olle Lind^{1,2} and Rachel Muheim^{1,*}

ABSTRACT

Many animals can use the polarization of light in various behavioural contexts. Birds are well known to use information from the skylight polarization pattern for orientation and compass calibration. However, there are few controlled studies of polarization vision in birds, and the majority of them have not been successful in convincingly demonstrating polarization vision. We used a two-alternative forced choice conditioning approach to assess linear polarization vision in male zebra finches in the 'visible' spectral range (wavelengths >400 nm). The birds were trained to discriminate colour, brightness and polarization stimuli presented on either one of two LCD-screens. All birds were able to discriminate the colour and brightness stimuli, but they were unable to discriminate the polarization stimuli. Our results suggest that in the behavioural context studied here, zebra finches are not able to discriminate polarized light stimuli.

KEY WORDS: Celestial polarization pattern, Avian vision, Vertebrate, E-vector orientation, Liquid crystal display (LCD), Choice experiments

INTRODUCTION

Many animals are able to perceive the polarization, i.e. the electric field vector (e-vector), of light, which is a fundamental visual quality besides the perception of brightness and colour (Nilsson and Warrant, 1999; Horváth, 2014). Linearly polarized light is abundant in nature; sunlight or moonlight becomes linearly polarized when scattered in the atmosphere and hydrosphere, or reflected from surfaces (Brines, 1980; Cronin et al., 2003; Horváth and Varjú, 2004). Animals can use polarized light in different contexts, such as camouflage breaking, orientation, navigation, water detection, interspecific communication, host finding and predator–prey detection (see Horváth, 2014 for recent reviews).

Polarization vision has been extensively studied in a variety of invertebrate taxa, like arthropods, crustaceans and cephalopods (for recent reviews, see Marshall and Cronin, 2014; Shashar, 2014; Zeil et al., 2014). Invertebrate polarization sensitivity is mediated by microvillar photoreceptors in which the orientation of light-absorbing pigments results in linear dichroism (Waterman and Horch, 1966; Rossel and Wehner, 1986; Roberts et al., 2011). In addition, effects of form dichroism, structural ordering in protein–visual pigment architecture and paracrystalline arrays of oligomerized visual pigments lead to highly differential absorption of linearly polarized light in many insects (Roberts et al., 2011).

In vertebrates, knowledge on polarization vision is still quite limited. The degree of orientation of light-absorbing visual molecules is not as high in ciliary photoreceptors of vertebrates as in the microvilli of the rhabdomeric photoreceptors of invertebrates (Roberts et al., 2011). Also, there is little evidence for ordered arrays of vertebrate photoreceptors comparable to the dorsal rim area found in many insects. Nevertheless, there is behavioural and physiological evidence for polarization sensitivity from all classes of vertebrates, apart from mammals (with the exception of humans) (for recent reviews, see Muheim, 2011; Åkesson, 2014; McGregor et al., 2014; Meyer-Rochow, 2014a; Meyer-Rochow, 2014b; Roberts, 2014). Amphibian and reptilian polarization sensitivity is primarily mediated by extraocular photoreceptors in the pineal gland (Adler and Taylor, 1973; Taylor and Adler, 1978), the frontal organ (Taylor and Ferguson, 1970; Justis and Taylor, 1976) and in the parietal eye (Freake, 1999; Beltrami et al., 2012). In fish, in contrast, polarization reception appears to be predominantly ocular, even though a role of the pineal gland cannot be excluded (Willis et al., 2009). Internal reflections in double cone and axial dichroisms of single cone photoreceptors in the fish retina have been suggested to form the basis of the polarization sensors in fish (Flamarique et al., 1998; Hawryshyn, 1992; Flamarique and Hárosi, 2002; Ramsden et al., 2008; Kamermans and Hawryshyn, 2011; Roberts, 2014).

Birds have been shown to use directional information from the skylight polarization patterns for compass orientation and as a calibration reference for their magnetic compass (Able, 1982; Phillips and Waldvogel, 1988; Phillips and Moore, 1992; Able and Able, 1993; Munro and Wiltshchko, 1995; Muheim et al., 2006a, 2009; reviewed by Muheim et al., 2006b; Muheim, 2011; Åkesson, 2014). Two early investigations found positive responses to polarized light stimuli in pigeons (*Columba livia*) trained to discriminate between light from rotating and fixed polarization filters (Kreithen and Keeton, 1974) or the orientation axis of linearly polarized light (Delius et al., 1976). The majority of conditioning experiments in birds, however, have been unsuccessful (Montgomery and Heinemann, 1952; Coemans et al., 1990, 1994; Hzn et al., 1995; Greenwood et al., 2003). Some of the earlier studies possibly neglected secondary cues, which could potentially have biased the results, and thus explain the positive responses to the polarized light stimuli (Coemans et al., 1990, 1994). In the study by Delius et al. (1976), the relatively large overhead polarized light source might have created light intensity artefacts from differential reflection of the linearly polarized light on the walls of the Skinner box. In that of Kreithen and Keeton (1974), imperfections in the rotating polarizing filter reflections off the adnexa of the eye, and possible corneal or lens diattenuation may have caused the birds to detect differences in light intensity as the e-vector was rotated. Thus, despite several decades of research it is still unclear to what degree and under which circumstances birds are able to perceive polarized light and discriminate polarization stimuli.

¹Lund Vision Group, Department of Biology, Lund University, Biology Building B, Sölvegatan 35, Lund SE-223 62, Sweden. ²Cognitive Science, Department of Philosophy, Lund University, LUX, Helgonavägen 3, Lund SE-223 62, Sweden.

*Author for correspondence (Rachel.Muheim@biol.lu.se)

Here, we tested linear polarization vision in zebra finches (*Taeniopygia guttata* Reichenbach) in the spectral range 400–700 nm using a two-alternative forced choice paradigm in an image-forming task. Stimuli contrasting in brightness and colour (hereafter called visible) or in the angle of linear polarization were presented on modified LCD-screens on either side of a cage (Fig. 1). This allowed for controlled rotation of the direction of polarization without changing intensity or spectral composition (Glantz and Schroeter, 2006; Pignatelli et al., 2011; Hanke et al., 2013; Temple et al., 2012). Initially, the birds were trained to associate food rewards with visible stimuli to produce a generalized behavioural response to any stimulus shown on the screens. Then, polarization stimuli were gradually introduced. At the final test level, the rewarded alternative was indicated by polarization stimuli alone.

RESULTS

We trained nine male zebra finches on three different training levels and one test level (see Materials and methods). First, we used visible stimuli only (level 1) or combinations of visible and polarization stimuli presented together in each trial (level 1.1). At level 2, the stimuli were combinations of visible and polarization stimuli (50% of trials) or isolated polarization stimuli (50% of trials). At level 3, 70% of the trials consisted of isolated polarization stimuli, and in the final test level, we presented polarization stimuli only.

Training levels

Three birds successfully completed level 1 (birds 865, 965, 254; Fig. 2A,D,H) and five birds completed level 1.1 successfully (birds 699, 896, 766, 869, 772; Fig. 2B,C,E,G), i.e. they scored a minimum of 80% correct choices in three consecutive or four out of five sessions. At both levels, we observed learning trends with a significant increase in the fraction of correct choices during training

(birds 865, 766, 869, 772, 254, 838; Fig. 2A,E–I). Three birds completed training successfully at level 2 (birds 865, 699, 896; Fig. 2A–C), but only one of them showed a learning trend (bird 896; Fig. 2C). No bird completed training successfully, nor showed any positive learning trend, at level 3 (Fig. 2A–I).

Test level

In the final test with only polarization stimuli, we pooled the data from all trials in each individual. The correct choice frequency of one bird (bird 766; Fig. 2E) was significantly above random (binomial test: choice frequency=0.58, $N=130$, $P=0.05$; supplementary material Table S1), and the correct choice frequency of a second bird (bird 772; Fig. 2G) was close to significant (binomial test: choice frequency=0.56, $N=140$, $P=0.08$; supplementary material Table S1). We found no significant learning trends for the test level in any individual.

DISCUSSION

Zebra finches do not learn to discriminate polarization stimuli in conditioning experiments

Despite successfully learning to associate the presence of visible stimuli on an LCD-screen with a food reward, our zebra finches did not learn to use polarized light stimuli presented in a similar way. Instead, the performance for discriminating polarization stimuli remained close to chance level (Fig. 2), while the performance for visible stimuli improved during the entire study (Fig. 3). These results are in line with previous unsuccessful attempts at demonstrating behavioural or physiological responses to polarized light in birds (Montgomery and Heinemann, 1952; Coemans et al., 1990, 1994; Greenwood et al., 2003). Thus, despite convincing behavioural evidence that birds use skylight polarization information for orientation and compass calibration (reviewed by Muheim, 2011), the original findings of polarization sensitivity in pigeons in an indoor setting (Kreithen and Keeton, 1974; Delius et al., 1976) have not been substantiated.

Possible explanations for the inability of the birds to discriminate polarization stimuli

Behavioural context

It is commonly accepted that migratory birds use information from the skylight polarization pattern as a directional reference to determine departure direction and for compass calibration (reviewed by Muheim, 2011; Åkesson, 2014). Studies testing the involvement of skylight polarization information in migratory orientation and homing typically include manipulated polarization patterns as directional cues, thus exploiting an innate or an already learned behavioural response to naturally existing stimuli (Able, 1982; Phillips and Waldvogel, 1988; Phillips and Moore, 1992; Able and Able, 1993; Munro and Wiltshcko, 1995; Muheim et al., 2006a, 2009; reviewed by Muheim et al., 2006b; Muheim, 2011). Other attempts to demonstrate polarization vision in birds, including the present study, used conditioning experiments. We trained zebra finches to associate polarization cues with specific locations of a food reward, more similar to landmark orientation than to orientation by the directional cues of sky patterns. If birds use polarized light information exclusively as a global directional reference, they might use the polarized light sense only in the appropriate context.

The studies on migratory orientation and homing (see above) indicate that birds are sensitive to the orientation of the e-vector of polarized light. Such polarization sensitivity does not necessarily encapsulate polarization vision, the ability to use polarized light in

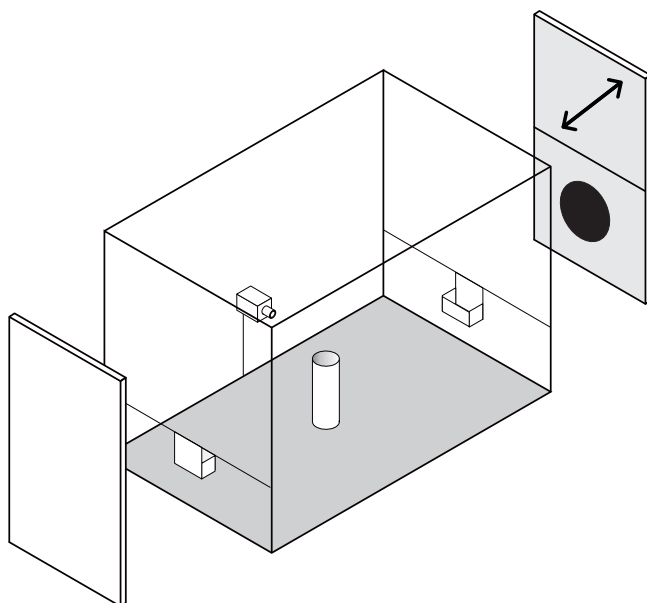

Fig. 1. Schematic drawing of the experimental setup. The stimuli were presented on two LCD-screens placed at the short sides of the experimental cage. Before a stimulus was presented, the bird had to perch on the circular perch in the centre of the cage. Two remotely controlled feeders (not shown) provided the birds with a standardized portion of millet seeds in the food trays in front of the screens. From a control room, the experimenter monitored the birds via a video camera and operated each screen with a separate laptop. The arrow on the upper half of the screen indicates a polarization stimulus, the filled circle on the lower half of the screen indicates a visible stimulus.

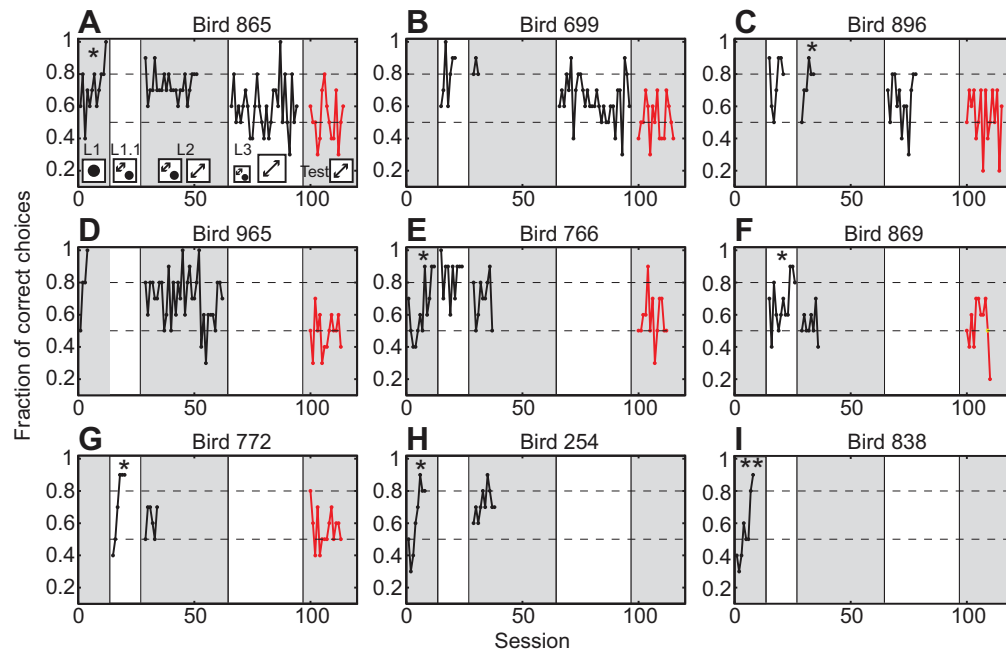

Fig. 2. Performance of the zebra finches for the different training levels and the test level. Data for nine different birds are shown in A–I. Black and red points give the fraction of correct choices for training and test sessions (blocks of 10 trials), respectively. The four training levels and test level are indicated in A: L1, visible stimuli; L1.1, combined stimuli (visible and polarization stimuli displayed simultaneously); L2, combined stimuli (50% of trials) and polarization stimuli (50% of trials); L3, combined stimuli (30% of trials) and polarization stimuli (70% of trials); test, polarization stimuli only. Significant learning trends in training and test levels were tested using Spearman rank correlation with low thresholds of significance to compensate for small sample sizes ($*P < 0.1$, $**P < 0.05$, r_s : A=0.59, C=79, E=0.65, F=0.50, G=0.94, H=0.85, I=0.88). Dashed lines indicate the random level of 50% correct choices and the level of 80% correct choices. Training was regarded as successfully completed when $\geq 80\%$ correct choices was obtained in three consecutive, or three out of four sessions. Note that not all birds were included at all levels.

an image-forming context. We initially trained zebra finches to associate food rewards with various brightness and colour patterns with the intention that this association would be transferred to polarization stimuli. Even if birds lack polarization vision, they could possibly use polarization sensitivity to solve the task of

associating a rotation in the angle of polarization with a food reward. However, the transfer of concepts established in an image-forming context to the task of using polarization sensitivity may be difficult, if not impossible. Thus, our initial training could have hampered rather than facilitated the learning of polarization cues. Similar problems could explain past failures to demonstrate avian polarization vision in behavioural paradigms such as a match-to-sample task (Greenwood et al., 2003), or pecking a key in a Skinner box under a specific alignment of the direction of polarization (Montgomery and Heinemann, 1952; Coemans et al., 1990, 1994). It could also explain why Delius et al. (1976) were successful in training birds to associate the spatial alignment of overhead linearly polarized light to the direction of a food reward in a modified Skinner box with four keys distributed on each side wall. This task is similar to the natural use of polarized skylight information as a global directional cue (Delius et al., 1976). However, the finding that pigeons discriminate between temporally separated stationary and rotating polarized light stimuli (Kreithen and Keeton, 1974) is inconsistent with this idea.

Experimental setup

The absence of ultraviolet (UV) light in our setup may be another explanation for the failure of the zebra finches to learn the polarized light stimuli. The LCD-screen stimuli in our experiments provided only weak or negligible amounts of light for the UV-sensitive cones of zebra finches (supplementary material Fig. S1). This is a drawback of using LCD-screens, which do not transmit light in the UV unless UV light is added to the screen behind the polarizing filter (Pignatelli et al., 2011). In many insects, UV light is necessary for sky polarization orientation (e.g. Duelli and Wehner, 1973; von Helversen and Edrich, 1974; reviewed by Zeil et al., 2014). Among

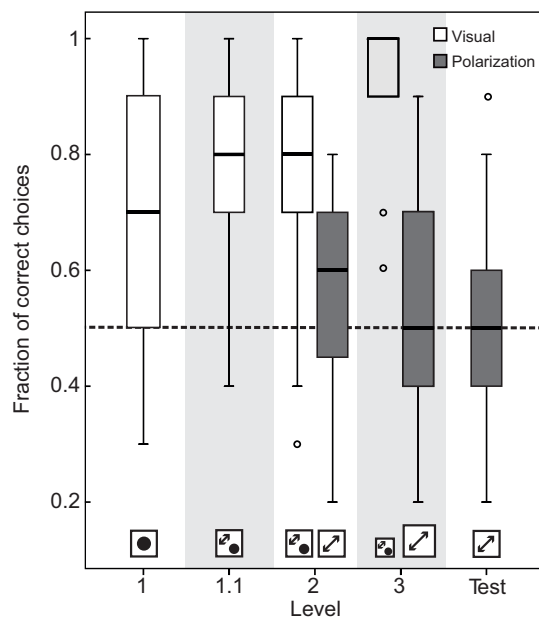

Fig. 3. Pooled performance of the birds for each level and stimulus type separately. The plots show the minimum and maximum value, the median and the first and third quartiles. Outliers are shown as open circles.

vertebrates, UV light is important for polarization vision in several species of fish (Mussi et al., 2005; Pignatelli et al., 2011). In species such as goldfish (*Carassius auratus*) and rainbow trout (*Oncorhynchus mykiss*) there appears to exist an opponent mechanism between a UV-sensitive and a long-wavelength-sensitive channel most sensitive to vertically and horizontally polarized light, respectively (Hawryshyn and McFarland, 1987; Ramsden et al., 2008). Information on the spectral properties of polarized light reception in other vertebrate classes is scarce. Lizards (*Podarcis* sp.) tested in a Morris water maze for e-vector orientation were oriented under short-wavelength light including wavelengths between 400 and 550 nm, but not at longer wavelengths (Beltrami et al., 2012). Birds are sensitive to UV light (Wright, 1972), and it has been suggested that they perceive polarized light in the near-UV region of the spectrum (Phillips and Waldvogel, 1988). However, the most favoured hypothesis for polarization vision in birds proposes a pathway initiated by medium- to long-wavelength-sensitive double cones (Young and Martin, 1984; Cameron and Pugh, 1991), which were readily stimulated in our experiments (supplementary material Fig. S1).

Conclusions

Our zebra finches did not learn to use polarization stimuli to locate a food reward. Our results support previous findings that it is extremely difficult to condition birds to a polarization angle contrast stimulus. Whether this depends on an intrinsic inability of birds to perceive polarized light, as some authors suggest (Coemans et al., 1990, 1994; Greenwood et al., 2003), or on our own inability to design an appropriate experimental assay is at the moment a question with no answer. Avian polarized light sensitivity remains one of the unresolved mysteries in sensory biology.

MATERIALS AND METHODS

Experimental animals

We used nine captive male zebra finches, between 3 and 6 years of age. The finches were kept at a low fat level corresponding to a fat class between 0 and 3 (Pettersson and Hasselquist, 1985). All experiments were carried out in accordance with the ethical permission from the Malmö-Lund Animal Ethics Committee, permits M 176-08, M 158-11 and M 423-12.

Experimental setup

The birds were tested for visible and linear polarization cues in two-alternative forced choice experiments with the stimuli presented on two LCD-screens (27 in Acer G276HL, Acer America Corporation, San Jose, CA, USA). The light used in the experiments was linearly polarized and in the spectral range 400–700 nm (see supplementary material Fig. S1).

The experiments were carried out in a rectangular cage (79×47×70 cm) located in the centre of the experimental room (Fig. 1). One screen was positioned behind each of the short sides of the cage, and a feeder was placed in front of the screens. A circular ‘starting’ perch (diameter 7 cm) was located in the centre of the cage, 90 cm from each of the two screens and 31 cm above the cage floor, so that the birds’ line of view was at the level of the centre of the screens. To reduce the horizontal viewing angle, the screens were installed upright, standing on their narrow side during experiments with polarized stimuli. Two remotely controlled pneumatic feeders were used to reward the birds for correct choices, providing the birds with standardized portions of millet seeds. The experiments were monitored and controlled from a visually isolated control room with a digital video camera and a separate laptop for each of the two screens (Fig. 1).

Stimuli

Three stimulus types were used during the experiments: (1) colour and brightness contrast stimuli (called visible stimuli) displayed on unmodified

screens (only level 1), (2) combined stimuli consisting of visible and polarization stimuli displayed simultaneously in the lower and upper half of modified screens, respectively, and (3) isolated polarization stimuli displayed on the upper half of modified screens while leaving the lower half of the screens unchanged. All the stimuli were produced in Microsoft PowerPoint 2010 and presented with Windows Live Photo gallery (Microsoft, Redmond, WA, USA). A response to the appearance of any of these stimuli was always reinforced with a food reward.

Visible stimuli (training level 1)

As very little is known about how polarized light is perceived by birds, a generalized response to any kind of stimuli shown on the screens was desirable. For this reason, we initially trained the birds to 20 different visible stimuli of various shapes, sizes, colours and brightness (see supplementary material Fig. S2), which were changed between every stimulus display.

Polarization stimuli (test level)

The polarization stimuli were created by removing the front polarizers of the two screens and displaying a black rectangle (27×16 cm) on the upper half of the modified screen so that the polarization angle of this field was rotated by 90 deg. The degree of polarization of the screens was initially 61% (white display mode) and 94% for the rotated stimulus (black display mode). We measured polarization stimuli using a radiometer (ILT1700 with detector SPM068-01, International Light, Peabody, MA, USA) with a rotatable linear polarization filter (same as above) placed in front of the detector (Johnsen, 2012). With the front polarizer of an LCD-screen removed, displayed images are manifested as polarization angle rotation with invariant colour and brightness, and thus are perceptible only by visual systems sensitive to linearly polarized light.

Combined visible and polarization stimuli (training levels 1.1, 2 and 3)

To display visible and polarization stimuli simultaneously, we reinstalled a new, functionally identical, polarizer (no. P500, 3Dlens Cooperation, Taipei, Taiwan; transmittance 43%, polarizing efficiency 99.9%, spectral range 380–700 nm) over the lower half of the screen. We presented the visible stimuli (supplementary material Fig. S2) on the lower half and the polarization stimuli (black rectangle) on the upper half of the screen, respectively.

Exclusion of secondary cues

We undertook the following precautions to avoid or control for secondary cues.

(1) The cage and all surfaces of the laboratory within the bird’s visual field were painted matt white or covered with matt white material to reduce reflections of highly polarized light (Kriska et al., 2006; Horváth et al., 2009). The degree and angle of polarization of light reflected from the experimental apparatus was scrutinized with photo-polarimetric methods as described in Horváth and Varjú (1997). Minor reflections were detected on the narrow sides of the cage. To disguise these cues, we disfavoured achromatic vision by shifting the test conditions away from the point of adaptation using a step increase in the ambient light intensity from 161 to 169 lx at the same moment as the stimuli were presented (in experimental level 3 or higher). Light intensity was kept at 169 lx as long as the stimulus was displayed.

(2) We measured the brightness (in candela) from the view point of the experimental birds when perching in the middle of the cage (see Fig. 1) with a radiometer (ILT1700 with detector SPM068-01, International Lights). The spectral output of the modified screens was measured with a spectroradiometer (RSP900-R; International Lights) using a 1000 µm light guide together with a radiance probe (acceptance angle <4 deg) pointed at 90 deg toward the screen, approximately 2 cm from the surface of the screen. The maximum difference in luminance between the ‘polarization stimuli’ state and the ‘non-stimuli’ state of the screens was about 7% Michelson contrast, which is below the 10% threshold of brightness discrimination and achromatic contrast sensitivity in birds (Hodos, 1993; Lind et al., 2012, 2013). The spectral output did not change with the presentation of polarization stimuli (supplementary material Fig. S1).

(3) Earlier experiments with modified screens have shown that viewing angle and edge effects from the contour of the stimuli are two additional factors that can potentially give rise to secondary cues (Glantz and Schroeter, 2006; Hanke et al., 2013). Therefore, we standardized the viewing angle during the entire study by presenting the stimuli to the birds only when they were located directly in front of the screens, thus constraining the maximal horizontal and vertical viewing angles to about 10 and 24 deg, respectively. To minimize the potential use of spatial vision for detection of stimulus edges, we used a smooth diffuse transition between the polarization stimuli and the surrounding area of the screen.

Experimental procedure

Before the start of the training trials, each bird was familiarized with the experimental setup by spending two 30 min sessions in the cage, together with up to two other birds. Subsequent training and testing were carried out individually. A trial was initiated once the bird was sitting on the circular perch for 5 s. The stimuli were presented in semi-random order on either one of the two screens, until the bird chose one of the feeders, but for no longer than 10 s. A bird was considered to have chosen a feeder when it perched on it, and the choice was considered to be correct if the chosen feeder was the one in front of the screen where the stimulus was being displayed. Trials were aborted if no choice was made within 10 s of stimulus presentation. For each correct choice, the bird was rewarded with a portion of millet seeds, and had to fly back to the circular perch to await the next presentation of a stimulus. The experimental sessions ended when the bird had either made between eight and 10 choices or had not shown any activity for more than 5 min. Between one and two experimental sessions per bird were run each day.

Training levels

The birds were trained at four different training levels. For each level, a bird was considered to have successfully passed the training once it had completed three consecutive, or four out of five, sessions with at least 80% correct choices.

On training level 1, the birds were trained with visible stimuli only. Training level 1.1 consisted of combined stimuli with both visible and polarization cues in every trial. On training level 2, the stimuli were a combination of visible and polarization cues (50% of trials) and isolated polarization stimuli (50% of trials). On training level 3, 70% of the trials consisted of isolated polarization stimuli, the rest of the trials were combined stimuli. Birds were included on levels 2 and 3 only if they had successfully passed previous training levels (see Fig. 2). Training levels 1 and 1.1 were considered equivalent to each other; consequently, most birds were trained on only one of these levels.

Test level

The test trials were carried out according to the same procedures as the training trials, but with only polarization stimuli presented.

Statistical analysis

The individual performances of the birds during the test level were analyzed with one-tailed binomial statistics. Training or test sessions were grouped into 10 consecutive trials for the statistical analysis (a trial being a stimulus display followed by a choice). Each of these series of 10 consecutive trials only contained trials within the same experimental level. Binomial statistical analyses for the test level were run on IBM® SPSS® Statistics 21 (Armonk, NY, USA) and Spearman rank correlation test for revealing learning trends (Fig. 2) were run on Matlab (R2014a, The MathWorks, Natick, MA, USA).

Acknowledgements

We would like to thank Adam Egri, Brian Dalton, Almut Kelber and Atticus Pinzon-Rodriguez for their valuable contributions to our work. We thank Atticus Pinzon-Rodriguez for drawing Fig. 1 and two anonymous reviewers for their valuable comments.

Competing interests

The authors declare no competing or financial interests.

Author contributions

J.M., O.L. and R.M. conceived and designed the experiments. J.M. carried out all testing, and J.M. and O.L. analysed the data. J.M., O.L. and R.M. wrote the paper.

Funding

This work was financially supported by the Swedish Research Council [2007-5700 and 2011-4765], the Crafoord Society [2010-1001 and 2013-0737], and the Royal Physiographical Society in Lund (all to R.M.). R.M. is a PI in the Centre of Animal Movement Research financed by a Linnaeus grant [349-2007-8690] from the Swedish Research Council and Lund University.

Supplementary material

Supplementary material available online at <http://jeb.biologists.org/lookup/suppl/doi:10.1242/jeb.122309/-/DC1>

References

- Able, K. P. (1982). Skylight polarization patterns at dusk influence migratory orientation in birds. *Nature* **299**, 550–551.
- Able, K. P. and Able, M. A. (1993). Daytime calibration of magnetic orientation in a migratory bird requires a view of skylight polarization. *Nature* **364**, 523–525.
- Adler, K. and Taylor, D. H. (1973). Extraocular perception of polarized light by orienting salamanders. *J. Comp. Physiol.* **87**, 203–212.
- Åkesson, S. (2014). The ecology of polarisation vision in birds. In *Polarized Light and Polarization Vision in Animal Sciences* (ed. G. Horváth), pp. 275–292. Berlin; Heidelberg: Springer.
- Beltrami, G., Parretta, A., Petrucci, F., Buttini, P., Bertolucci, C. and Foà, A. (2012). The lizard celestial compass detects linearly polarized light in the blue. *J. Exp. Biol.* **215**, 3200–3206.
- Brines, M. L. (1980). Dynamic patterns of skylight polarization as clock and compass. *J. Theor. Biol.* **86**, 507–512.
- Cameron, D. A. and Pugh, E. N. (1991). Double cones as a basis for a new type of polarization vision in vertebrates. *Nature* **353**, 161–164.
- Coemans, M. A. J. M., Vos Hzn, J. J. and Nuboer, J. F. W. (1990). No evidence for polarization sensitivity in the pigeon. *Naturwissenschaften* **77**, 138–142.
- Coemans, M., Hzn, J. and Nuboer, J. (1994). The orientation of the e-vector of linearly polarized light does not affect the behaviour of the pigeon, *Columba livia*. *J. Exp. Biol.* **191**, 107–123.
- Cronin, T. W., Shashar, N., Caldwell, R. L., Marshall, J., Cheroske, A. G. and Chiou, T.-H. (2003). Polarization vision and its role in biological signaling. *Integr. Comp. Biol.* **43**, 549–558.
- Delius, J. D. M., Perchard, R. J. and Emmerton, J. (1976). Polarized light discrimination by pigeons and an electroretinographic correlate. *J. Comp. Physiol. Psychol.* **90**, 560–571.
- Duelli, P. and Wehner, R. (1973). The spectral sensitivity of polarized light orientation in *Cataglyphis bicolor* (Formicidae, Hymenoptera). *J. Comp. Physiol.* **86**, 37–53.
- Flamarique, I. N. and Hárosi, F. I. (2002). Visual pigments and dichroism of anchovy cones: A model system for polarization detection. *Vis. Neurosci.* **19**, 467–473.
- Flamarique, I. N., Hawryshyn, C. W. and Hárosi, F. I. (1998). Double-cone internal reflection as a basis for polarization detection in fish. *J. Opt. Soc. Am. A* **15**, 349–358.
- Freake, M. J. (1999). Evidence for orientation using the e-vector direction of polarized light in the sleepy lizard, *Tiliqua rugosa*. *J. Exp. Biol.* **202**, 1159–1166.
- Glantz, R. M. and Schroeter, J. P. (2006). Polarization contrast and motion detection. *J. Comp. Physiol. A* **192**, 905–914.
- Greenwood, V. J., Smith, E. L., Church, S. C. and Partridge, J. C. (2003). Behavioural investigation of polarisation sensitivity in the Japanese quail (*Coturnix coturnix japonica*) and the European starling (*Sturnus vulgaris*). *J. Exp. Biol.* **206**, 3201–3210.
- Hanke, F. D., Miersch, L., Warrant, E. J., Mitschke, F. M. and Dehnhardt, G. (2013). Are harbour seals (*Phoca vitulina*) able to perceive and use polarised light? *J. Comp. Physiol. A* **199**, 509–519.
- Hawryshyn, C. W. (1992). Polarization vision in fish. *Am. Sci.* **80**, 164–175.
- Hawryshyn, C. W. and McFarland, W. N. (1987). Cone photoreceptor mechanisms and the detection of polarized light in fish. *J. Comp. Physiol. A* **160**, 459–465.
- Hodos, W. (1993). The visual capabilities of birds. In *Vision, Brain, and Behavior in Birds* (ed. H. P. Zeigler and H.-J. Bischof), pp. 63–66. USA: Massachusetts Institute of Technology.
- Horváth, G. (2014). *Polarized Light and Polarization Vision in Animal Sciences*. Berlin; Heidelberg: Springer.
- Horváth, G. and Varjú, D. (1997). Polarization pattern of freshwater habitats recorded by video polarimetry in red, green and blue spectral ranges and its relevance for water detection by aquatic insects. *J. Exp. Biol.* **200**, 1155–1163.
- Horváth, G. and Varjú, D. (2004). *Polarized Light in Animal Vision*. Berlin; Heidelberg: New York: Springer.
- Horváth, G., Kriska, G., Malik, P. and Robertson, B. (2009). Polarized light pollution: a new kind of ecological photopollution. *Front. Ecol. Environ.* **7**, 317–325.

- Hzn, J., Coemans, M. and Nuboer, J. (1995). No evidence for polarization sensitivity in the pigeon electroretinogram. *J. Exp. Biol.* **198**, 325–335.
- Johnsen, S. (2012). *The Optics of Life: a Biologist's Guide to Light in Nature*. Princeton: Princeton University Press.
- Justis, C. S. and Taylor, D. H. (1976). Extraocular photoreception and compass orientation in larval bullfrogs, *Rana catesbeiana*. *Copeia* **1976**, 98–105.
- Kamerlings, M. and Hawryshyn, C. (2011). Teleost polarization vision: how it might work and what it might be good for. *Philos. Trans. R. Soc. B Biol. Sci.* **366**, 742–756.
- Kreithen, M. L. and Keeton, W. T. (1974). Detection of polarized light by the homing pigeon, *Columba livia*. *J. Comp. Physiol.* **89**, 83–92.
- Kriska, G., Malik, P., Csabai, Z. and Horváth, G. (2006). Why do highly polarizing black burnt-up stubble-fields not attract aquatic insects? An exception proving the rule. *Vision Res.* **46**, 4382–4386.
- Lind, O., Sunesson, T., Mitkus, M. and Kelber, A. (2012). Luminance-dependence of spatial vision in budgerigars (*Melopsittacus undulatus*) and Bourke's parrots (*Neopsephotus bourkii*). *J. Comp. Physiol. A* **198**, 69–77.
- Lind, O., Karlsson, S. and Kelber, A. (2013). Brightness discrimination in budgerigars (*Melopsittacus undulatus*). *PLoS ONE* **8**, e54650.
- Marshall, J. and Cronin, T. (2014). Polarisation vision of crustaceans. In *Polarized Light and Polarization Vision in Animal Sciences* (ed. G. Horváth), pp. 171–216. Berlin; Heidelberg: Springer.
- McGregor, J., Temple, S. E. and Horváth, G. (2014). Human polarization sensitivity. In *Polarized Light and Polarization Vision in Animal Sciences* (ed. G. Horváth), pp. 303–315. Berlin; Heidelberg: Springer.
- Meyer-Rochow, V. B. (2014a). Polarization sensitivity in amphibians. In *Polarized Light and Polarization Vision in Animal Sciences* (ed. G. Horváth), pp. 249–263. Berlin; Heidelberg: Springer.
- Meyer-Rochow, V. B. (2014b). Polarization sensitivity in reptiles. In *Polarized Light and Polarization Vision in Animal Sciences* (ed. G. Horváth), pp. 265–274. Berlin; Heidelberg: Springer.
- Montgomery, K. C. and Heinemann, E. G. (1952). Concerning the ability of homing pigeons to discriminate patterns of polarized light. *Science* **116**, 454–456.
- Muheim, R. (2011). Behavioural and physiological mechanisms of polarized light sensitivity in birds. *Philos. Trans. R. Soc. B Biol. Sci.* **366**, 763–771.
- Muheim, R., Phillips, J. B. and Åkesson, S. (2006a). Polarized light cues underlie compass calibration in migratory songbirds. *Science* **313**, 837–839.
- Muheim, R., Moore, F. R. and Phillips, J. B. (2006b). Calibration of magnetic and celestial compass cues in migratory birds - a review of cue-conflict experiments. *J. Exp. Biol.* **209**, 2–17.
- Muheim, R., Phillips, J. B. and Deutschlander, M. E. (2009). White-throated sparrows calibrate their magnetic compass by polarized light cues during both autumn and spring migration. *J. Exp. Biol.* **212**, 3466–3472.
- Munro, U. and Wiltschko, R. (1995). The role of skylight polarization in the orientation of a day-migrating bird species. *J. Comp. Physiol. A* **177**, 357–362.
- Mussi, M., Haimberger, T. J. and Hawryshyn, C. W. (2005). Behavioural discrimination of polarized light in the damselfish *Chromis viridis* (family Pomacentridae). *J. Exp. Biol.* **208**, 3037–3046.
- Nilsson, D.-E. and Warrant, E. J. (1999). Visual discrimination: seeing the third quality of light. *Curr. Biol.* **9**, R535–R537.
- Pettersson, J. and Hasselquist, D. (1985). Fat deposition and migration capacity of robins *Erithacus rebeccula* and goldcrests *Regulus regulus* at Ottenby, Sweden. *Ring. Migr.* **6**, 66–76.
- Phillips, J. B. and Moore, F. (1992). Calibration of the sun compass by sunset polarized light patterns in a migratory bird. *Behav. Ecol. Sociobiol.* **31**, 189–193.
- Phillips, J. B. and Waldvogel, J. A. (1988). Celestial polarized light patterns as a calibration reference for sun compass of homing pigeons. *J. Theor. Biol.* **131**, 55–67.
- Pignatelli, V., Temple, S. E., Chiou, T.-H., Roberts, N. W., Collin, S. P. and Marshall, N. J. (2011). Behavioural relevance of polarization sensitivity as a target detection mechanism in cephalopods and fishes. *Philos. Trans. R. Soc. B Biol. Sci.* **366**, 734–741.
- Ramsden, S. D., Anderson, L., Mussi, M., Kamerlings, M. and Hawryshyn, C. W. (2008). Retinal processing and opponent mechanisms mediating ultraviolet polarization sensitivity in rainbow trout (*Oncorhynchus mykiss*). *J. Exp. Biol.* **211**, 1376–1385.
- Roberts, N. W. (2014). Polarisation vision of fishes. In *Polarized Light and Polarization Vision in Animal Sciences* (ed. G. Horváth), pp. 225–247. Berlin; Heidelberg: Springer.
- Roberts, N. W., Porter, M. L. and Cronin, T. W. (2011). The molecular basis of mechanisms underlying polarization vision. *Philos. Trans. R. Soc. B Biol. Sci.* **366**, 627–637.
- Rossel, S. and Wehner, R. (1986). Polarization vision in bees. *Nature* **323**, 128–131.
- Shashar, N. (2014). Polarization vision in cephalopods. In *Polarized Light and Polarization Vision in Animal Sciences* (ed. G. Horváth), pp. 217–224. Berlin; Heidelberg: Springer.
- Taylor, D. H. and Adler, K. (1978). The pineal body: site of extraocular perception of celestial cues for orientation in the tiger salamander (*Ambystoma tigrinum*). *J. Comp. Physiol. A* **124**, 357–361.
- Taylor, D. H. and Ferguson, D. E. (1970). Extraoptic celestial orientation in the southern cricket frog *Acris gryllus*. *Science* **168**, 390–392.
- Temple, S. E., Pignatelli, V., Cook, T., How, M. J., Chiou, T.-H., Roberts, N. W. and Marshall, N. J. (2012). High-resolution polarisation vision in a cuttlefish. *Curr. Biol.* **22**, R121–R122.
- von Helversen, O. and Edrich, W. (1974). Der Polarisationsempfänger im Bienenaugen: ein Ultraviolettzeptor. *J. Comp. Physiol.* **94**, 33–47.
- Waterman, T. H. and Horch, K. W. (1966). Mechanism of polarized light perception. *Science* **154**, 467–475.
- Willis, J., Phillips, J., Muheim, R., Diego-Rasilla, F. J. and Hobday, A. J. (2009). Spike dives of juvenile southern bluefin tuna (*Thunnus maccoyii*): a navigational role? *Behav. Ecol. Sociobiol.* **64**, 57–68.
- Wright, A. A. (1972). The influence of ultraviolet radiation on the pigeon's color discrimination. *J. Exp. Anal. Behav.* **17**, 325–337.
- Young, S. R. and Martin, G. R. (1984). Optics of retinal oil droplets: a model of light collection and polarization detection in the avian retina. *Vision Res.* **24**, 129–137.
- Zeil, J., Ribí, W. A. and Narendra, A. (2014). Polarisation vision in ants, bees and wasps. In *Polarized Light and Polarization Vision in Animal Sciences* (ed. G. Horváth), pp. 41–60. Berlin; Heidelberg: Springer.