

## RESEARCH ARTICLE

# The effect of water temperature and flow on respiration in barnacles: patterns of mass transfer versus kinetic limitation

 Michael T. Nishizaki<sup>1,2,\*</sup> and Emily Carrington<sup>1,2</sup>
**ABSTRACT**

In aquatic systems, physiological processes such as respiration, photosynthesis and calcification are potentially limited by the exchange of dissolved materials between organisms and their environment. The nature and extent of physiological limitation is, therefore, likely to be dependent on environmental conditions. Here, we assessed the metabolic sensitivity of barnacles under a range of water temperatures and velocities, two factors that influence their distribution. Respiration rates increased in response to changes in temperature and flow, with an interaction where flow had less influence on respiration at low temperatures, and a much larger effect at high temperatures. Model analysis suggested that respiration is mass transfer limited under conditions of low velocity ( $<7.5 \text{ cm s}^{-1}$ ) and high temperature (20–25°C). In contrast, limitation by uptake reaction kinetics, when the biotic capacity of barnacles to absorb and process oxygen is slower than its physical delivery by mass transport, prevailed at high flows (40–150  $\text{cm s}^{-1}$ ) and low temperatures (5–15°C). Moreover, there are intermediate flow-temperature conditions where both mass transfer and kinetic limitation are important. Behavioral monitoring revealed that barnacles fully extend their cirral appendages at low flows and display abbreviated ‘testing’ behaviors at high flows, suggesting some form of mechanical limitation. In low flow–high temperature treatments, however, barnacles displayed distinct ‘pumping’ behaviors that may serve to increase ventilation. Our results suggest that in slow-moving waters, respiration may become mass transfer limited as temperatures rise, whereas faster flows may serve to ameliorate the effects of elevated temperatures. Moreover, these results underscore the necessity for approaches that evaluate the combined effects of multiple environmental factors when examining physiological and behavioral performance.

**KEY WORDS:** Barnacles, Intertidal, Respiration, Thermal stress, Mass transfer limitation

**INTRODUCTION**

Given the fluctuating nature of intertidal zones, marine biologists have had long-standing interests in the degree to which environmental variation influences the distribution and abundance of species (Barry et al., 1995; Southward et al., 1995; Underwood et al., 1983). Predicting the outcome of species–environment interactions, however, can be limited by a poor understanding of physiological sensitivity (Denny and Helmuth, 2009; Seebacher and Franklin, 2012; Shelford,

1911). Indeed, recent attempts to forecast species distribution under changing climatic conditions have focused on key physiological mechanisms (Denny and Gaylord, 2010; Gaston, 2009; Kearney et al., 2009). One such mechanism is metabolism, which reflects an organism’s ability to convert energy into materials that support important life functions such as movement, growth and reproduction (Hochachka and Somero, 2002). Metabolic activity, when used to construct physiological performance curves, can provide a means of describing an organism’s sensitivity to changing environmental conditions (Huey and Kingsolver, 1989).

Although temperature is among the most important factors influencing metabolic rate in marine invertebrates, a range of patterns have been documented including linear increase, decrease or the existence of thermal optima (Bruce, 1926; Jansen et al., 2009; Matoo et al., 2013). Similarly, the effect of flow on respiration is unclear as some organisms show a positive relationship (Patterson and Sebens, 1989; Thomas and Atkinson, 1997), whereas others display little to no sensitivity (Edmunds, 2005). These discrepancies are likely rooted in: (1) the narrow range of conditions tested compared with those experienced by organisms in their natural environments; and/or (2) the interactive effects of temperature and flow on physiological rates (Edmunds, 2005). Here, we combined experiments and models to assess the metabolic sensitivity of barnacles to a wide range of water temperatures and velocities, two environmental factors that correlate with their distribution (Leonard et al., 1998; Wetthey, 1983).

Many biological functions such as respiration, photosynthesis and calcification, depend on the uptake of dissolved nutrients and/or gases (Burriss et al., 1983; Cornelisen and Thomas, 2004; Sebens et al., 1997). These uptake rates, in turn, are potentially limited by: (1) the transport rates of dissolved material from the water column to the surface of an organism (known as mass transfer limitation); or (2) reaction kinetics at the boundary that limit the ability of an organism to assimilate the dissolved material across the body wall (reaction kinetic limitation) (Gerard, 1982; Patterson and Sebens, 1989; Stevens and Hurd, 1997). Knowing whether uptake rates are governed by mass transfer versus kinetic limitation is important in understanding whether physiological processes are regulated by factors internal versus external to the organism. For instance, if an organism is mass transfer limited, adaptations that increase the physical delivery of oxygen to the organism will be favored, such as increased ventilation rates in *Mytilus edulis* under reduced oxygen tension (Bayne, 1971) or the use of respiratory proteins with high oxygen affinities by crustaceans in low-oxygen environments (Childress and Seibel, 1998). In contrast, during periods of kinetic limitation, physiological control of uptake is relatively more important (Seibel and Childress, 2013), resulting in a different set of responses. For instance, when marine snails experience aerial exposure, oxygen delivery is rarely limiting, yet metabolic responses to thermal change do occur (Marshall et al., 2011; McMahon and Russell-Hunter, 1977). These thermal responses are likely limited

<sup>1</sup>Department of Biology, University of Washington, Box 351800, Seattle, WA 98195-1800, USA. <sup>2</sup>Friday Harbor Laboratories, Friday Harbor, WA 98250, USA.

\*Author for correspondence at present address: Department of Integrative Biology, University of Guelph, Guelph, ON, Canada N1G 2W1. (mnishiza@uoguelph.ca)

by physiological processes that are based on enzyme reaction rates (Somero, 1969). Indeed, determining whether uptake rates are mass transfer versus kinetically limited is a pervasive theme in biology that spans across the majority of the world's taxa (e.g. plants and animals) and environments (e.g. air or water) (for reviews, see Denny, 1993; Dubinsky and Stambler, 2011; Koch et al., 2006).

Mass transfer limitation occurs as a consequence of dissolved materials needing to be physically delivered from the water column to the surface of the organism. To do so, solutes must penetrate through the boundary layer that surrounds various surfaces of an organism and the factors that limit this delivery are largely physical in nature. Increasing velocities reduce the thickness of diffusional boundary layers (Schlichting et al., 2000) and Fick's law predicts that the flux of a solute to or from a surface is inversely related to boundary layer thickness (Mass et al., 2010; Patterson et al., 1991). Thus, mass transfer between an organism and the water column should increase with faster flow. In contrast, the effects of water temperature on mass transfer rates are far less clear. Cooler waters contain more dissolved oxygen and have greater diffusivity, which should increase oxygen delivery rates. However, lower temperatures also increase viscosity and thus boundary layer thickness, which may decrease mass transfer rates. In considering these opposing processes, increases in diffusivity appear to have the most profound influence on oxygen mass transfer (Denny, 1993).

Kinetic limitation can occur when there is sufficient solute delivered to the organism and mass transfer limitation eases. Under these conditions, uptake rates may be limited by reaction kinetics, related to the ability of an organism to assimilate oxygen across the body surface. Barnacles possess a chitinous cuticle (Koulish, 1981) that potentially slows oxygen uptake as diffusion through chitin is much slower (4%) than diffusion through water (Krogh, 1919). Hemolymph circulation represents an additional rate-limiting step as hemolymph pressure in balanomorphs is low and circulation is largely driven by body/cirral movements as opposed to a heart (Waite and Walker, 1986). As respiratory pigments are generally absent in balanomorph barnacles (Southward, 1963; Waite and Walker, 1988), it is likely that diffusion across the cuticle and circulation represent the most important aspects of kinetic limitation.

For instance, uptake of nutrients in freshwater plants has been shown to occur more slowly than does transport across their diffusional boundary layers (Nishihara and Ackerman, 2006). Reaction kinetics, in this case, may be more limiting than any rate of mass transfer.

Performance curves link physiological responses to environmental factors and are important in identifying whether an organism experiences mass transfer versus kinetic limitation. In aquatic systems, mass transfer limitation has been documented at low water velocities ( $>5$  to  $30 \text{ cm s}^{-1}$ ) in algae (Hurd et al., 1996), corals (Patterson et al., 1991; Thomas and Atkinson, 1997; Mass et al., 2010; Brown and Carpenter, 2013) and seagrasses (Mass et al., 2010). In contrast, kinetic limitation has been documented in freshwater plants (Nishihara and Ackerman, 2009) and algae (Gerard, 1982; Hurd et al., 1996). The degree of mass transfer limitation also varies with solute concentration and type. For instance, seagrasses maintained under replicate flow conditions were mass transfer limited for ammonia but not nitrate (Cornelisen and Thomas, 2004). Together, these results underscore the need for a detailed examination of how environmental conditions may or may not influence uptake rates.

Many organisms engage in behavioral strategies that have significant effects on their physiology (Huey and Stevenson, 1979). In barnacles, the activity of modified appendages called cirri may represent an important coupling of physiological and behavioral

systems. Cirri may contribute to respiratory exchange in barnacles (Anderson and Southward, 1987; Newell and Northcroft, 1965), in addition to serving as feeding appendages. Cirral activity is known to vary with both temperature (Anderson and Southward, 1987; Newell and Northcroft, 1965; Ritz and Foster, 1968) and flow (Marchinko, 2007; Miller, 2007). Simultaneous monitoring of respiration and beating rate under a range of temperatures and flows will provide a more comprehensive comparison of barnacle physiology and behavior.

In this study, we used the barnacle *Balanus glandula* Darwin 1854 to investigate physiological and behavioral responses to varying water temperature and velocity. *Balanus glandula* is a well-known, cosmopolitan species that can be found on temperate rocky shores in both the northern and southern hemispheres (Barnes and Barnes, 1956; Geller et al., 2008). As an intertidal organism, *B. glandula* is subject to a wide range of both water temperatures (Berger, 2009) and velocities (Marchinko, 2007; Miller, 2007; Neufeld and Palmer, 2008). Although much interest exists in the effect of multiple factors on respiratory physiology, few studies have sufficient resolution to produce appropriate performance curves in a fully crossed design (Moran and Woods, 2010). In this study: (1) we constructed a series of performance curves to explore the influence of water temperature and velocity on respiration rate; (2) we assessed the relative importance of mass transfer versus kinetic limitation of respiration rates; and (3) we measured cirral activity under different water temperatures and velocities to explore the interactions between environment, physiology and behavior.

## RESULTS

### Field conditions

A total of 38,759 water temperature measurements were recorded at Argyle Creek, San Juan Island, WA, USA, between June 2011 and August 2012. Temperature was not recorded from 9 August 2011 to 17 August 2011 when probes were collected and redeployed. Temperature varied between 2.5 and 26.7°C (Fig. 1).

### Respiration rate

Mean respiration rate ranged 20-fold in response to changing water temperature and flow conditions ( $2.8$ – $60.4 \text{ nmol O}_2 \text{ g}^{-1} \text{ s}^{-1}$ ; Fig. 2). Respiration rate rose more rapidly from 5 to 15°C than from 15 to 25°C [mean  $\pm$  s.e.m. temperature coefficients ( $Q_{10}$ ) averaged over all flows were  $2.69 \pm 0.25$  and  $1.57 \pm 0.10$ , respectively].

Respiration rate displayed a curvilinear response to increased water velocity, saturating at velocities above  $7.5$ – $12 \text{ cm s}^{-1}$  (Fig. 2).

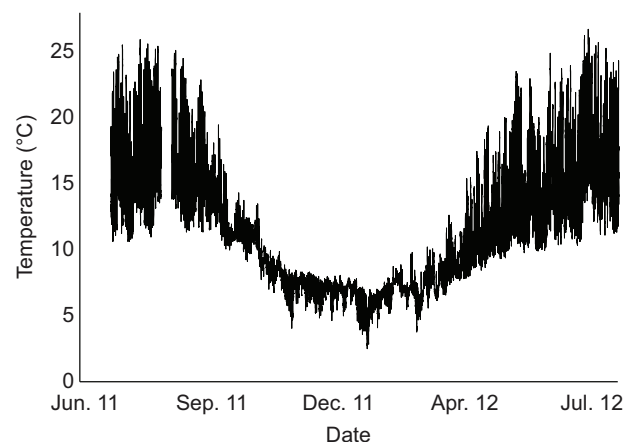
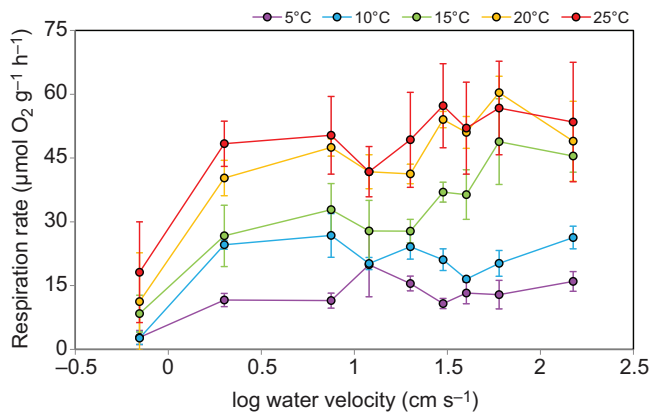

Fig. 1. Seasonal water temperatures from Argyle Creek, WA, USA, from June 2011 to August 2012. Water temperature was sampled every 15 min.



**Fig. 2. Respiration rate response as a function of water temperature and velocity for *Balanus glandula*.** Colored lines represent different temperatures. Error bars represent one standard error.  $N=3$  plates.

Mean respiration rate was typically low at slow velocities (e.g.  $8.6 \pm 2.9 \text{ nmol O}_2 \text{ g}^{-1} \text{ s}^{-1}$  at  $0.7 \text{ cm s}^{-1}$ ), rose rapidly as flows increased to  $7.5 \text{ cm s}^{-1}$  ( $33.8 \pm 7.1 \text{ nmol O}_2 \text{ g}^{-1} \text{ s}^{-1}$ ), and remained stable to  $150 \text{ cm s}^{-1}$  ( $38.0 \pm 7.2 \text{ nmol O}_2 \text{ g}^{-1} \text{ s}^{-1}$ ).

There was a significant interaction between the two main effects, water temperature and water velocity ( $F_{32,64}=3.756$ ,  $P<0.05$ ). At low temperatures ( $5\text{--}10^\circ\text{C}$ ), flow had little influence on respiration rate, whereas at high temperatures ( $20\text{--}25^\circ\text{C}$ ), flow had a much larger effect (Fig. 2).

#### Sherwood number–Reynolds number analysis

Sherwood number ( $Sh$ )–Reynolds number ( $Re$ ) plots indicate that oxygen uptake was flow dependent at slow water velocities ( $\leq 7.5 \text{ cm s}^{-1}$ ; Fig. 3), as evidenced by high  $Re$  exponents across all temperatures ( $0.73 \pm 0.13$ ). In contrast, lower  $Re$  exponents at higher velocities ( $0.18 \pm 0.05$  for  $>7.5 \text{ cm s}^{-1}$ ), indicated that uptake was relatively flow independent. Alternatively,  $Sh$  derived from fluid transport processes displayed higher  $Re$  exponents at both low and high flows ( $1.01 \pm 0.04$  for velocities  $\leq 7.5 \text{ cm s}^{-1}$  and  $0.98 \pm 0.013$  for velocities  $>7.5 \text{ cm s}^{-1}$ ).

#### Mass transfer versus kinetic limitation

The non-dimensional plot based on Sanford and Crawford (Sanford and Crawford, 2000) demonstrates that barnacle respiration rate can

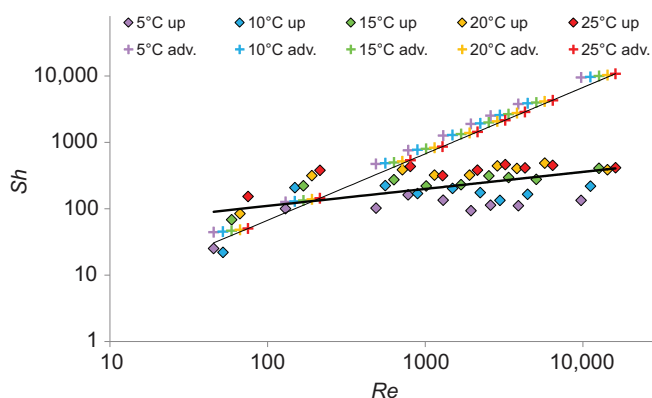

**Fig. 3. Non-dimensional plot of Sherwood number ( $Sh$ ) as a function of Reynolds number ( $Re$ ).** Values based on total oxygen consumption rates are represented by diamonds; crosses represent Sherwood numbers based on advective/diffusive transport.

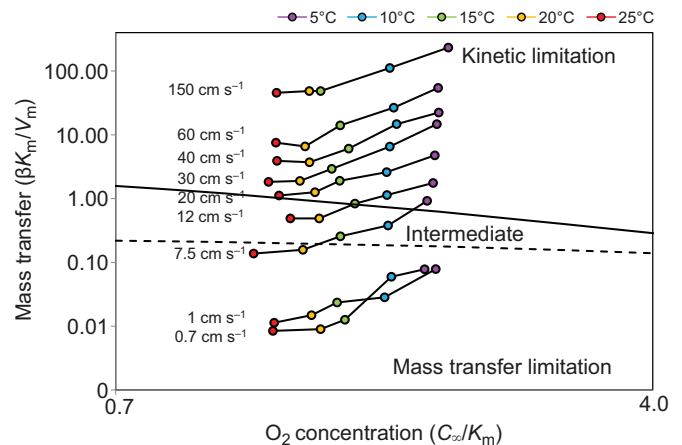

**Fig. 4. Non-dimensional mass transfer coefficient ( $\beta K_m/V_m$ ) plotted against non-dimensional oxygen saturation ( $C_\infty/K_m$ ).** Each circle is calculated from means of three trials of the respiration experiment; colors indicate different temperature treatments and each line represents trials conducted under the same water velocity, as indicated on the graph. The solid line represents the upper limit for conditions of mass transfer limitation and the dashed line represents the lower limit for conditions of kinetic limitation.  $\beta$  is the mass transfer velocity ( $\text{m s}^{-1}$ ),  $V_m$  is the maximum uptake rate ( $\mu\text{mol O}_2 \text{ m}^{-2} \text{ h}^{-1}$ ),  $K_m$  is the oxygen concentration at which the uptake rate is one-half of its maximum ( $\mu\text{mol O}_2 \text{ m}^{-3}$ ) and  $C_\infty$  is oxygen concentration in the bulk flow.

be mass transfer and/or kinetically limited, depending on the temperature–flow conditions they experience (Fig. 4). Barnacles in low flow conditions ( $0.7 \text{ cm s}^{-1}$ ) were under mass transfer limitation at all temperatures above  $5^\circ\text{C}$ . Barnacles at slightly higher flows, between  $1$  and  $7.5 \text{ cm s}^{-1}$ , were generally under mass transfer limitation at warmer temperatures but entered kinetic limitation under cooler temperatures. Barnacles at  $12\text{--}40 \text{ cm s}^{-1}$  were in the intermediate region, where both mass transfer and kinetic limitation occurs, at warm temperatures and kinetic limitation at high temperatures. Barnacles at or above  $60 \text{ cm s}^{-1}$  were generally limited by reaction kinetics.

#### Cirral beating behavior

At low temperature ( $5^\circ\text{C}$ ), the frequency of both abbreviated and extended beating behaviors was limited ( $<23\%$  and  $26\%$ , respectively; Fig. 5). At intermediate temperatures ( $10\text{--}20^\circ\text{C}$ ), barnacles generally displayed extended beating at low flows and abbreviated beating at high flows. These abbreviated beats primarily consisted of gaping or testing beats. At the highest temperature ( $25^\circ\text{C}$ ), barnacles displayed elevated levels of abbreviated beating when water velocities were low ( $<2 \text{ cm s}^{-1}$ ). These abbreviated beats consisted mainly of pumping behavior.

The results of the two-way repeated measures ANOVA indicated that temperature was a significant predictor of total beating activity ( $F_{4,8}=4.886$ ,  $P<0.05$ ), whereas water velocity was not ( $F_{8,16}=1.295$ ,  $P>0.05$ ). Water velocity was a significant factor influencing both extended ( $F_{8,16}=6.018$ ,  $P<0.05$ ) and abbreviated beating ( $F_{8,16}=2.616$ ,  $P<0.05$ ). In contrast, water temperature had little effect on either extended ( $F_{4,8}=0.818$ ,  $P>0.05$ ) or abbreviated ( $F_{4,8}=3.057$ ,  $P>0.05$ ) beating.

#### DISCUSSION

##### Metabolic response to temperature and flow

Barnacle respiration rates varied between  $3$  and  $60 \mu\text{mol O}_2 \text{ g}^{-1} \text{ h}^{-1}$  and showed a positive relationship with temperature regardless of



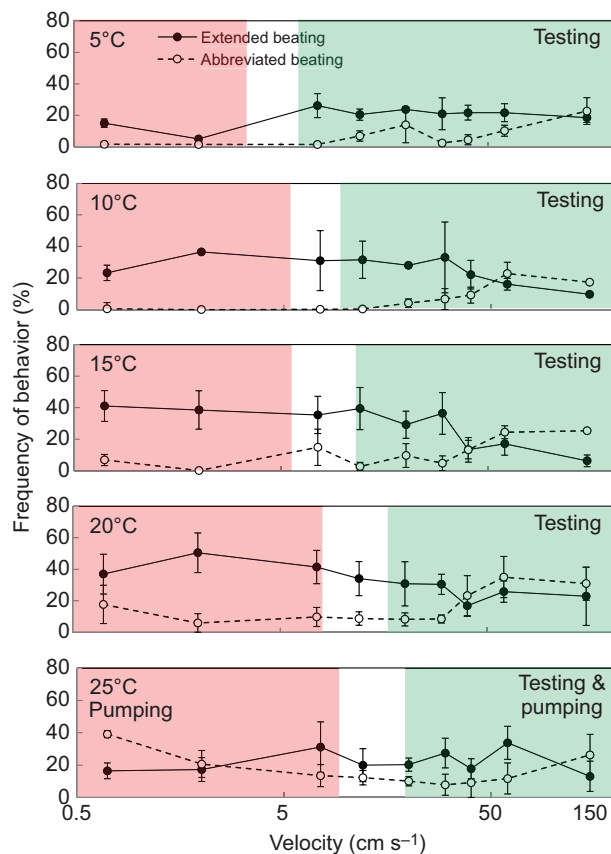

**Fig. 5. Cirral behavior of barnacles under varying water temperatures and velocities.** Behaviors (see Anderson and Southward, 1987) include 'extended beating' with cirri fully extended (i.e. normal beating, slow beating, fast beating and cirral extension) and a category of abbreviated beating (testing, pumping and gaping). The pink region represents conditions of mass transfer limitation, the green region represents kinetic limitation and the white region indicates intermediate conditions. Error bars represent one standard error.  $N=3$  plates.

flow condition. Respiration increased from low to moderate temperatures (5–20°C), and saturated at high temperatures (20–25°C). Although respiration rate generally increased with increased temperature, this temperature dependency was stronger at low temperatures ( $Q_{10}=2.69\pm 0.25$  for 5–15°C) than at high temperatures ( $Q_{10}=1.57\pm 0.10$  for 15–25°C), suggesting a peak at or above 20–25°C.

The rates reported here are consistent with previous measures of barnacle respiration [ $14\ \mu\text{mol O}_2\ \text{g}^{-1}\ \text{h}^{-1}$  (Barnes and Barnes, 1969);  $4$  to  $67\ \mu\text{mol O}_2\ \text{g}^{-1}\ \text{h}^{-1}$  (Wu and Levings, 1978)]. Similarly, our temperature coefficients approximate those measured in mussels [ $Q_{10}=1.4$ – $2.1$  (Widdows, 1973)], urchins [ $Q_{10}=1.7$ – $3.0$  (Siikavuopio et al., 2008)], hermit crabs [ $Q_{10}=1.4$ – $1.6$  (Burggren and McMahon, 1981)] and shore crabs [ $Q_{10}=2.2$ – $2.4$  (Greenaway et al., 1996)].

For barnacles under kinetic limitation (Fig. 4), respiration rates had temperature coefficients ( $Q_{10}$ ) of 2.92 from 5 to 15°C and 1.42 from 15 to 25°C. To what extent do these respiratory changes match known responses in biochemical/physiological processes? Oxygen dissociation rates for myoglobins in teleost fish have a  $Q_{10}$  of 1.17–2.36 for temperatures ranging from 5 to 20°C (Cashon et al., 1997). Diffusion of oxygen through peritoneum tissue (vertebrate) had a  $Q_{10}$  of 1.09 for temperatures ranging from 15 to 36°C (Krogh, 1919). Similarly, activity rates of citrate synthase,

a pace-making enzyme in the Krebs cycle, are also temperature dependent. In crustaceans, citrate synthase  $Q_{10}$  was 1.78–1.84 between 5 and 15°C and 1.56–1.61 between 20 and 30°C (Salomon and Buchholz, 2000). Moreover, the relative magnitudes of our respiration rates appear to be generally consistent with the rate of known biochemical/physiological processes. Our respiratory response curves also displayed a pattern of hyperbolic saturation as small increases in water velocity at the lowest flows resulted in large increases in respiration rate, whereas further increases at high velocities had little effect on respiration (Fig. 2). Our flow-mediated response was similar to the respiratory response of corals (Finelli et al., 2006; Patterson and Sebens, 1989; Patterson et al., 1991), nutrient uptake in seagrasses (Cornelisen and Thomas, 2004) and the photosynthetic response in aquatic plants (Nishihara and Ackerman, 2006; Stewart and Carpenter, 2003).

Our non-dimensional analyses indicate that respiration rates are generally mass transfer limited under low velocity–high temperature conditions and kinetically limited at high velocity–low temperature conditions (Fig. 4). Lower water temperatures may lead to kinetic limitation due to higher levels of dissolved  $\text{O}_2$ . One of the few previous reports of kinetic limitation focused on coral respiration (Edmunds, 2005) and found that respiration rate was independent of flow (kinetic limitation) at low temperatures, but dependent on flow (mass transfer limited) at high temperatures (Edmunds, 2005). A second example of kinetic limitation comes from measurements of nutrient uptake and photosynthesis in the freshwater plant *Vallisneria americana* (Nishihara and Ackerman, 2009). The thermal maximum for photosynthesis in *V. americana* from the Great Lakes region is 32.6°C (Titus and Adams, 1979), which is higher than the temperature (24°C) tested by Nishihara and Ackerman (Nishihara and Ackerman, 2009). This is consistent with our conclusion that kinetic limitation is likely to be limited to the lower temperature range of a species.

Respiration under kinetically limited conditions is potentially limited by both  $\text{O}_2$  absorption/circulation rates and reduced metabolic cost. In decapod crustaceans, low temperatures (1°C) result in decreased oxygen hemolymph concentrations, lower circulation rates and increased anaerobic respiration (Frederich and Pörtner, 2000). This suggests that aerobic activity was limited by circulation rate rather than decreased metabolic demand. For barnacles at low temperatures, slow cirral movement was observed, suggesting that low circulation rate may be a limiting factor.

Given the dependence of respiration rate on temperature and flow, it is reasonable to ask how frequently barnacles experience mass transfer versus kinetic limitation in the field. At wave-sheltered sites, water velocities are typically in the mass transfer limited region [ $0.96\pm 0.1\ \text{cm s}^{-1}$ , measured 5 cm above the substrate (Marchinko, 2003)], whereas at more exposed barnacle sites [mean velocity= $98\ \text{cm s}^{-1}$  (Miller, 2007)], respiration rates are most likely to be limited by reaction kinetics. However, these velocities may themselves be an overestimate of those experienced by barnacles, as water motion near boundaries where barnacles are found may be greatly reduced from free-stream velocities. For instance, velocities within a mussel aggregation may be as little as 0.1–9% of free-stream values (Carrington et al., 2008; O'Donnell, 2008). Similarly, water temperatures monitored at the Argyle Creek collection site suggest that barnacles potentially experience mass transfer limited conditions (e.g. water temperature above 20°C) for 5.2% of the year (Fig. 1). Furthermore, if one considers a 1.5°C rise in sea surface temperature as is predicted over the next century (Meehl et al.,

2011), the time that barnacles experience mass transfer limited conditions rises to 6.3%.

Although body temperature does not directly correlate with air temperature (Helmuth, 1998; Denny and Harley, 2006), it is likely that conditions of mass transfer limitation exist for many barnacles under field conditions.

### Cirral behavior

Temperature influenced the proportion of barnacles displaying extended beating (i.e. thermal optima at 20°C; Fig. 5), consistent with many related species of barnacle (for review, see Anderson and Southward, 1987). Under low flows (<20 cm s<sup>-1</sup>), barnacles typically displayed extended beating behaviors. Marchinko (Marchinko, 2007) observed extended cirral activity from wave-exposed barnacles up to the maximum tested velocity (49 cm s<sup>-1</sup>), whereas wave-sheltered barnacles ceased feeding when water velocities reached between 7.5 and 21.4 cm s<sup>-1</sup>. We had similar results for our wave-sheltered barnacles; animals in high water velocities (>40 cm s<sup>-1</sup>) switched to ‘testing’ behavior. This is likely due to the mechanical deformation of cirri experience under high velocities (≥21.4 cm s<sup>-1</sup>) and a subsequent switch to abbreviated lower drag behaviors [≥33 cm s<sup>-1</sup> (Marchinko, 2007)]. Increased ‘pumping’ behavior under low flow–high temperature conditions is similar to observations made by Anderson and Southward (Anderson and Southward, 1987), who describe a ‘respiratory pumping beat’. In corals, a similar but slower behavior of tentacle extension has been interpreted as a strategy to increase the diffusive surface available for O<sub>2</sub> exchange (Kühl et al., 1995; Shashar et al., 1993). For barnacles, rapid cirral beating may increase oxygen uptake through both passive (i.e. increasing surface area) and active (i.e. disturbing boundary layers) means.

Our results underscore the need to consider multiple environmental factors when assessing physiological performance. The degree to which barnacle respiration is under mass transfer versus kinetic limitation depends on both water temperature and velocity. For example, studies conducted under low flows might only observe mass transfer limitation, whereas experiments run only at cool temperatures might only see kinetic limitation. As our results demonstrate, only a comprehensive survey of the temperature–flow landscape may reveal patterns of mass transfer and kinetic limitation.

The advantages of employing factorial experiments become even more pronounced when one considers the impact of rising ocean temperatures (Levitus et al., 2000). Our results suggest that we might expect different physiological responses to elevated temperatures on wave-sheltered versus wave-exposed shores. For instance, in areas with slow moving waters, barnacle physiology may become increasingly mass transfer limited as water temperatures rise. In contrast, at wave-exposed sites, faster water velocities may ameliorate the effects of rising temperatures on mass transfer limitation. Our results are consistent with the hypothesis that oxygen limitation may restrict the ecological distribution of marine organisms by lowering thermal tolerance (Pörtner and Knust, 2007). Moreover, our results demonstrate the limitation of inferences drawn from single-factor designs, and strongly advocate approaches that consider interactions among multiple factors.

## MATERIALS AND METHODS

### Organism collection

Adult barnacles (*B. glandula*) attached to mussel shells (*Mytilus trossulus*) were collected from Argyle Creek (48°31.728'N, 123°00.802'W) on San Juan Island, WA, USA, between August and September 2010. Flow in this

saltwater creek is largely unidirectional as the shallow corridor (~10 m across) connects a lagoon to a bay that fills and drains during tidal exchanges. Water depth at the site varied between 10 and 50 cm and maximum creek width was ~10 m. Water velocity in Argyle Creek ranged from 0.01 to 1.37 m s<sup>-1</sup> over a 12 h tidal cycle as measured with an Acoustic Doppler Velocimeter (Sontek/YSI Inc., San Diego, CA, USA) at two locations spanning ~30 m in the streamwise direction. Water velocity at each site was sampled at 25 Hz for 180 s every hour from a sampling volume that was maintained more than 1 cm above the substratum (where barnacles were found) to avoid boundary layer effects.

Temperature at Argyle Creek was measured every 15 min from June 2011 to August 2012 with a submersible temperature probe (HOBO U22 Water Temp Pro v2; Onset Computer Corporation, Bourne, MA, USA) to estimate the range of thermal conditions that barnacles experience in the field throughout a typical year.

All barnacles were maintained in unfiltered, flowing seawater at the Friday Harbor Labs where water temperature ranged from 11 to 14°C and salinity remained relatively constant at 30 psu. Barnacles were maintained under laboratory conditions for less than 2 weeks before use in experiments. Individual barnacles, with their calcareous basal plate intact, were gently removed from mussel shells with a razor blade and attached to an acrylic plate (10×3 cm) using ZSpar (A-788 Splash Zone Epoxy, Kop-Coat Inc., Pittsburgh, PA, USA). Each plate contained between 69 and 73 barnacles and a total of three replicate plates were used in each experimental treatment.

### Measuring respiration rate

Experiments were conducted in a closed, recirculating flow chamber of 600 ml volume (Fig. 6). A clear acrylic test chamber (3×3×15 cm, H×W×L) was connected to a submersible pump (Models 25D/27D, Rule Industries, Gloucester, MA, USA) via low gas permeability Tygon tubing (19 mm i.d.). Water velocities along the centerline of the testing chamber were estimated by tracking the displacement of glass microbeads at each flow setting (mean particle diameter 9 μm, density 2.0 g cm<sup>-3</sup>; Potters Industries, Malvern, PA, USA). The entire flow chamber was submersed in a water bath that was temperature regulated by a re-circulating water chiller (±0.1°C; Ecoline RE 106, Lauda, Germany).

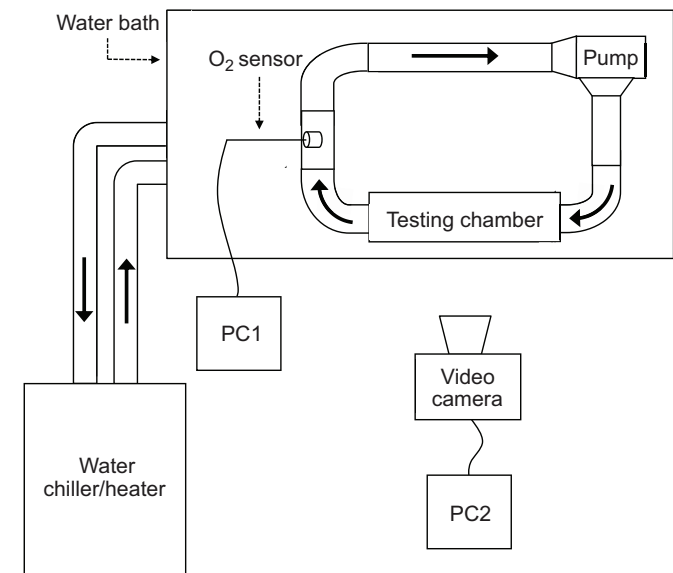

**Fig. 6. Schematic diagram of the recirculating flow chamber used to measure respiration rate.** Flow rates were controlled by a submersible pump and temperatures were set using a water chiller (±0.1°C). Bold arrows indicate the direction of water flow through the system. Oxygen concentrations were measured via an optical probe inserted into the chamber and recorded to a laptop (PC1). Drift in control runs without barnacles was less than 0.6% h<sup>-1</sup>. Barnacle behavior was recorded directly to a computer (PC2) in digital video format. Dimensions are not to scale.

Oxygen concentration was measured using a fiber-optic oxygen sensor equipped with a needle-like probe tip of 1.5 mm diameter (FOXY-R, Ocean Optics, Dunedin, FL, USA). The probe contained a complex constructed from the hydrophobic material ruthenium. When blue light (475 nm) is directed through the probe, the ruthenium complex excites and fluoresces at a wavelength of 600 nm. In the presence of oxygen, the intensity of this emission decays predictably and the rate of this emission quenching is used to estimate oxygen concentration. It should be noted that the rate of  $\text{Ru}^{2+}\text{-O}_2$  association is five times faster than the disassociation rate; thus, attempts to measure changes in  $\text{O}_2$  concentration greater than  $10 \mu\text{mol O}_2 \text{ l}^{-1} \text{ min}^{-1}$  do not allow for the establishment of proper binding equilibrium (Glazer et al., 2004). In our experiments, the rate of change in  $\text{O}_2$  concentration was lower than this threshold and the results are, therefore, considered accurate. The probe was calibrated at each temperature with a two-point calibration at 0% (oxygen reduced with sodium dithionite) and 100% (oxygen-saturated) seawater filtered to  $1 \mu\text{m}$ . The probe was extremely sensitive to temperature fluctuations, necessitating tight control of temperature in the flow chamber ( $\pm 0.1^\circ\text{C}$ ). Samples were recorded at a rate of 0.5 Hz and drift of the probe was negligible ( $<0.3\%$  over 30 min at  $20^\circ\text{C}$  and  $7.5 \text{ cm s}^{-1}$ ).

Barnacles were first acclimated in fully oxygenated water at the testing temperature for 60 min before being acclimated for 5 min in the testing chamber. Barnacles were exposed 15 times to the same order of nine randomized water velocities (12, 20, 2, 40, 0.7, 7.5, 30, 60 and  $150 \text{ cm s}^{-1}$ ) with the first velocity ( $12 \text{ cm s}^{-1}$ ) being repeated at the end of the trials to ensure that the barnacle's physiology had not changed over the course of the experiment ( $t_{14}=2.14$ ,  $P=0.33$ ). Barnacles were also tested three times under a specific order of temperature treatments (20, 10, 5, 15 and  $25^\circ\text{C}$ ) with no two temperatures tested on the same day. No differences in respiration rate were found at the beginning and end of the experimental trials ( $t_2=4.30$ ,  $P=0.30$ ). A total of 45 trials were run until  $\sim 25\%$  of the oxygen in the flow chamber was consumed (typically 30 min to 2 h) and a stable rate of decline could be identified. Oxygen concentrations were standardized by dry barnacle body mass (g), where barnacle body (prosoma + cirri) was removed from the test with watchmaker forceps and dried at  $60^\circ\text{C}$  for 72 h.

### Analysis

Temperature coefficients ( $Q_{10}$ ) describing the magnitude of change in respiration with increasing temperature were calculated as:

$$Q_{10} = \left( \frac{R_1}{R_2} \right)^{\left( \frac{10}{T_1 - T_2} \right)}, \quad (1)$$

where  $R_1$  and  $R_2$  are respiration rates ( $\mu\text{mol O}_2 \text{ g}^{-1} \text{ h}^{-1}$ ), and  $T_1$  and  $T_2$  are corresponding temperatures ( $^\circ\text{C}$ ).

Respiration rates were analyzed using a two-way repeated-measures ANOVA, with water temperature and velocity as repeated factors. When the assumption of sphericity, that covariances between each level of a repeated measures factor are equal, was not satisfied, a Huynh–Feldt correction was employed (Zar, 1999). Paired comparisons were made using the Holm–Sidak method. Analysis was conducted using MATLAB R2011a (MathWorks, Natick, MA, USA).

### Sherwood–Reynolds number analysis

Two non-dimensional indices were calculated to examine how advection affects the mass flux of oxygen from the water column to barnacles. The first, called the Reynolds number  $Re$ , is a ratio of inertial to viscous forces of a fluid:

$$Re = \frac{U\rho l}{\nu}, \quad (2)$$

where  $U$  is water velocity ( $\text{m s}^{-1}$ ),  $\rho$  is water density ( $\text{kg m}^{-3}$ ), is the characteristic dimension of the organism (barnacle diameter, m), and  $\nu$  is the kinematic viscosity ( $\text{m}^2 \text{ s}^{-1}$ ).

The Sherwood number  $Sh$  represents the ratio of advective mass (oxygen) flux to diffusive mass flux (Campbell, 1977):

$$Sh = \frac{h_m l}{D}, \quad (3)$$

where  $D$  is the diffusion coefficient for oxygen ( $\text{m}^2 \text{ s}^{-1}$ ) and  $h_m$  is the mass transfer coefficient ( $\text{m s}^{-1}$ ), which was determined empirically from the ratio of the average mass flux of oxygen assisted by convection to the oxygen concentration difference between the chamber and the site of aerobic respiration and photosynthesis.

If barnacles are under kinetic limitation, mass transfer coefficients calculated from total oxygen consumption in the chamber may underestimate the potential for advective mass transfer. For comparison,  $Sh$  numbers were calculated using a form of  $h_m$  that relates the ability of diffusion versus fluid flow to deliver oxygen (see  $\beta_{\text{rough}}$  in Eqn 7 in 'Determining mass transfer versus kinetic limitation', below).

Plots of  $Sh$  (ordinate) versus  $Re$  (abscissa) were used to describe how water motion affects mass transfer (Patterson and Sebens, 1989):

$$Sh = aRe^b, \quad (4)$$

where  $a$  is an empirical coefficient that is dependent on barnacle shape and  $b$  is the flow-dependent exponent (Patterson and Sebens, 1989). Slopes from least squared regression analysis of the  $Sh$ – $Re$  relationship were used to estimate the flow exponent of Eqn 4.

### Determining mass transfer versus kinetic limitation

A comparison of the relative importance of mass transfer versus reaction kinetics in limiting respiration rate was conducted using the non-dimensional approach described previously (Sanford and Crawford, 2000). A short description of the method is provided below.

To begin, mass transfer flux ( $F$ ) of oxygen can be estimated as (Sanford and Crawford, 2000):

$$F = \beta (C_\infty - C_0), \quad (5)$$

where  $F$  is flux ( $\mu\text{mol O}_2 \text{ m}^{-2} \text{ s}^{-1}$ ),  $\beta$  is mass transfer velocity ( $\text{m s}^{-1}$ ),  $C_\infty$  is the bulk fluid concentration ( $\mu\text{mol O}_2 \text{ ml}^{-1}$ ) at a distance from the boundary and  $C_0$  is the concentration at the boundary ( $\mu\text{mol O}_2 \text{ ml}^{-1}$ ).  $C_\infty$  was measured from the free-stream portion of the flow chamber.

Flux over a rough surface (i.e. barnacles), however, can be calculated as (Bilger and Atkinson, 1992):

$$F_{\text{rough}} = St_{m,\text{rough}} U_b (C_\infty - C_0), \quad (6)$$

where  $St_{m,\text{rough}}$  is the Stanton number (a non-dimensional ratio of  $\text{O}_2$  flux to advection past an object) for mass transfer in flow over a rough surface and  $U_b$  is the bulk velocity of seawater in the flow chamber ( $\text{cm s}^{-1}$ ).

Mass transfer velocity can be calculated as the product of the Stanton number and bulk velocity (Cussler, 2009; Sharma, 2007):

$$\beta_{\text{rough}} = St_{m,\text{rough}} U_b, \quad (7)$$

with (Bilger and Atkinson, 1992):

$$St_{m,\text{rough}} = E St_{m,\text{smooth}}, \quad (8)$$

where  $E$  is the enhancement factor for a rough surface (non-dimensional), which can be calculated as (Bilger and Atkinson, 1992):

$$E = 1.94 Sc^{0.09} Re_{\text{rough}}^{-0.10}, \quad (9)$$

where  $Sc$  is the Schmidt number, a non-dimensional ratio of the diffusivity of momentum to that of molecules.  $Re_{\text{rough}}$  is the roughness Reynolds number for seawater flowing over barnacles (non-dimensional) (Bilger and Atkinson, 1992):

$$Sc = \nu / D, \quad (10)$$

$$Re_{\text{rough}} = (u^* k') / \nu, \quad (11)$$

where  $D$  is  $\text{O}_2$  diffusivity ( $\text{m}^2 \text{ s}^{-1}$ ),  $u^*$  is friction velocity ( $\text{m s}^{-1}$ ) and  $k'$  is the height of roughness elements (m). Friction velocity over barnacles was estimated at each velocity using the linear relationship between  $U$  and  $u^*$  based on values reported in the literature for water flowing over a rough surface (Fig. 7;  $u^* = 0.1112U + 0.3448$ ). As the data are limited to  $30 \text{ cm s}^{-1}$ , a linear extrapolation was assumed at higher water velocities.

Stanton number for flow over a smooth surface can be calculated as (Bilger and Atkinson, 1992):

$$St_{m,\text{smooth}} = \left( \frac{c_f}{2} \right)^{-\frac{1}{2}} (0.0575 Sc^{-\frac{2}{3}} + 0.1184 Sc^{-1}), \quad (12)$$



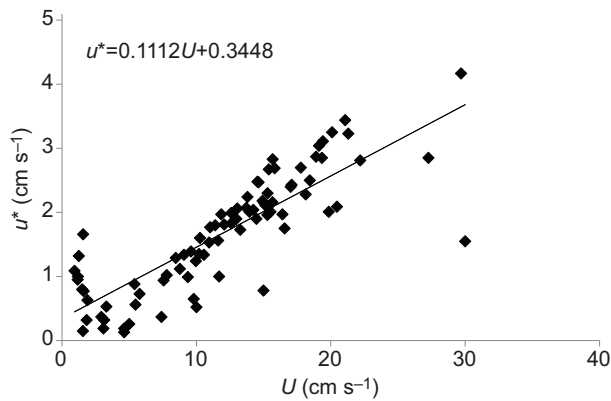

**Fig. 7. Friction velocity ( $u^*$ ) as a function of free-stream water velocity ( $U$ ) over aggregations of benthic aquatic invertebrates.** Aquatic invertebrates included corals, marine/freshwater mussels and oysters. Data are from previous studies (Ackerman et al., 2001; Finelli et al., 2007; Fréchet et al., 1989; fig. 2 of Matoo et al., 2013).

with:

$$\left(\frac{c_f}{2}\right)^{-\frac{1}{2}} = -5.1 \log_{10}\left(\frac{6.9}{Re_{smooth}}\right), \quad (13)$$

where  $c_f$  is the friction coefficient.

Reaction kinetics, or the uptake rate at a solid–liquid boundary, can be described by Michaelis–Menten kinetics, with uptake rates saturating at high concentrations:

$$R = \frac{V_m C_0}{K_m + C_0}, \quad (14)$$

where  $R$  is the reaction rate ( $\mu\text{mol O}_2 \text{ m}^{-2} \text{ h}^{-1}$ ),  $V_m$  is the maximum uptake rate ( $\mu\text{mol O}_2 \text{ m}^{-2} \text{ h}^{-1}$ ) and  $K_m$  is oxygen concentration at which the uptake rate is one half of its maximum ( $\mu\text{mol O}_2 \text{ m}^{-3}$ ). To estimate the kinetic parameters  $V_m$  and  $K_m$ , oxygen uptake rates were fitted to the Michaelis–Menten model using non-linear regression analysis (Kemmer and Keller, 2010).

Solving for steady-state uptake rate can then be achieved by equating Eqns 5 and 14:

$$R = \frac{V_m C_0}{K_m + C_0} = \beta(C_\infty - C_0). \quad (15)$$

A non-dimensional solution (see Sanford and Crawford, 2000) is derived by dividing Eqn 15 by  $V_m C_\infty / K_m$ :

$$\frac{RK_m}{V_m C_\infty} = \left[ \frac{C_\infty}{K_m} + \frac{1}{2} \left( \gamma + \sqrt{\gamma^2 + 4 \frac{C_\infty}{K_m}} \right) \right]^{-1}, \quad (16)$$

where

$$\gamma = 1 + \left( \frac{\beta K_m}{V_m} \right)^{-1} - \frac{C_\infty}{K_m}. \quad (17)$$

From this relationship, one can calculate the non-dimensional uptake rate ( $RK_m/V_m C_\infty$ ), the non-dimensional mass transfer coefficient ( $\beta K_m/V_m$ ) and the non-dimensional oxygen concentration coefficient ( $C_\infty/K_m$ ). A non-dimensional plot of mass transfer rate versus the oxygen concentration is presented with thresholds delineating whether barnacles in the different treatments are under mass transfer versus kinetic limitation (see Results). Following previous methods (Sanford and Crawford, 2000), thresholds are defined as 25% deviations from the full solution for uptake rates. For instance, conditions under mass transfer limitation were defined as:

$$\frac{\beta K_m}{V_m} < \frac{0.25}{1 + \frac{C_\infty}{K_m}}, \quad (18)$$

whereas conditions where reaction kinetics were limiting were defined as (Sanford and Crawford, 2000):

$$\frac{\beta K_m}{V_m} > \frac{4 + 0.8 \frac{C_\infty}{K_m}}{\left(1 + \frac{C_\infty}{K_m}\right)^2}. \quad (19)$$

These thresholds for kinetic and mass transfer limitation were used to delineate mass transfer limitation, kinetic limitation and intermediate regions on plots of  $\beta K_m/V_m$  versus  $C_\infty/K_m$ .

### Cirral beating behavior

During the respiration experiment, cirral beating behavior of barnacles was recorded directly to a PC using a 3-CCD digital video camera (Model PV-GS150, Panasonic of North America, Secaucus, NJ, USA). The digital video was used to assess cirral motion using an open-source processing software package (Avidemux 2.5.4). Preliminary tests indicated that a capture rate of 15 Hz was sufficient to measure all forms of cirral behavior. Ten barnacles were randomly selected for each of three replicate trials at each of the temperature $\times$ velocity treatments ( $N=45$ , based on 1350 barnacles). For each barnacle, cirral behaviors were classified and the proportion of time barnacles spent engaged in each behavior was calculated. Behaviors were classified using criteria described elsewhere (Anderson and Southward, 1987) and subsequently assigned to one of two categories: (1) extended behaviors, which included normal beating, slow beating, fast beating and cirral extension; and (2) abbreviated behaviors which included testing, pumping and gaping (Anderson and Southward, 1987). Cirral beating behaviors were assessed from 10 min video clips coinciding with respiration trials.

Two-way repeated measures ANOVA with Holm–Sidak method for individual comparisons were used to assess differences in the frequency of beating activity under different temperatures and water velocities. Frequencies were assessed for: (1) abbreviated beating, (2) extended beating and (3) total beating (abbreviated + extended beating). When the assumption of sphericity was not satisfied, a Huynh–Feldt correction was employed (Zar, 1999). Analysis was conducted using MATLAB R2011a (MathWorks).

### Acknowledgements

We thank H. Hayford, C. Neufeld and D. Vaughn for comments on an early version of the manuscript, S. Gilman, K. Sebens and A. Summers for advice on experimental design and T. Wang and N. LeBaron for assistance with video analysis. The data in this manuscript are archived with the Biological and Chemical Oceanography Data Management Office as project no. 473867.

### Competing interests

The authors declare no competing financial interests.

### Author contributions

M.T.N. and E.C. contributed to the conception of experiments and data analysis, as well as the drafting and revising of the paper. M.T.N. led the data collection.

### Funding

Funding was provided by the National Science Foundation [no. OCE0824903 to E.C.] and the Stephen and Ruth Wainwright Endowed Fellowship, Alan J. Kohn Endowed Fellowship, Kathryn C. Hahn Writing Fellowship and University of Washington Biology Department – Friday Harbor Laboratories Award to M.T.N.

### References

- Ackerman, J. D., Loewen, M. R. and Hamblin, P. F. (2001). Benthic-pelagic coupling over a zebra mussel reef in western Lake Erie. *Limnol. Oceanogr.* **46**, 892–904.
- Anderson, D. and Southward, A. (1987). Cirral activity of barnacles. In *Barnacle Biology* (ed. A. Southward), pp. 135–174. Rotterdam, Netherlands: A. A. Balkema.
- Barnes, H. and Barnes, M. (1956). The general biology of *Balanus glandula* Darwin. *Pac. Sci.* **10**, 415–422.
- Barnes, H. and Barnes, M. (1969). Seasonal changes in the acutely determined oxygen consumption and effect of temperature for three common cirripedes, *Balanus balanoides* (L.), *B. balanoides* (L.) and *Chthamalus stellatus* (Poli). *J. Exp. Mar. Biol. Ecol.* **4**, 36–50.
- Barry, J. P., Baxter, C. H., Sagarin, R. D. and Gilman, S. E. (1995). Climate-related, long-term faunal changes in a California rocky intertidal community. *Science* **267**, 672–675.

- Bayne, B. L. (1971). Ventilation, the heart beat and oxygen uptake by *Mytilus edulis* L. in declining oxygen tension. *Comp. Biochem. Physiol.* **40A**, 1065-1085.
- Berger, M. (2009). Reproduction of the intertidal barnacle *Balanus glandula* along an estuarine gradient. *Mar. Ecol. Prog. Ser.* **37**, 261-272.
- Bilger, R. W. and Atkinson, M. J. (1992). Anomalous mass transfer of phosphate on coral reef flats. *Limnol. Oceanogr.* **37**, 261-272.
- Brown, A. L. and Carpenter, R. C. (2013). Water-flow mediated oxygen dynamics within massive *Porites*-algal turf interactions. *Mar. Ecol. Prog. Ser.* **490**, 1-10.
- Bruce, J. R. (1926). The respiratory exchange of the mussel (*Mytilus edulis*, L.). *Biochem. J.* **20**, 829-846.
- Burggren, W. and McMahon, B. (1981). Oxygen uptake during environmental temperature change in hermit crabs: adaptation to subtidal, intertidal, and supratidal habitats. *Physiol. Zool.* **54**, 325-333.
- Burris, J., Porter, J. and Laing, W. (1983). Effects of carbon dioxide concentration on coral photosynthesis. *Mar. Biol.* **75**, 113-116.
- Campbell, G. (1977). *An Introduction to Environmental Biophysics*. Berlin: Springer-Verlag.
- Carrington, E., Moeser, G. M., Thompson, S. B., Coutts, L. C. and Craig, C. A. (2008). Mussel attachment on rocky shores: the effect of flow on byssus production. *Integr. Comp. Biol.* **48**, 801-807.
- Cashon, R. E., Vayda, M. E. and Sidell, B. D. (1997). Kinetic characterization of myoglobins from vertebrates with vastly different body temperatures. *Comp. Biochem. Physiol.* **117B**, 613-620.
- Childress, J. J. and Seibel, B. A. (1998). Life at stable low oxygen levels: adaptations of animals to oceanic oxygen minimum layers. *J. Exp. Biol.* **201**, 1223-1232.
- Cornelisen, C. and Thomas, F. (2004). Ammonium and nitrate uptake by leaves of the seagrass *Thalassia testudinum*: impact of hydrodynamic regime and epiphyte cover on uptake rates. *J. Mar. Syst.* **49**, 177-194.
- Cussler, E. L. (2009). *Diffusion: Mass Transfer in Fluid Systems*. Cambridge: Cambridge University Press.
- Denny, M. W. (1993). *Air and Water: The Biology and Physics of Life's Media*. Princeton, NJ: Princeton University Press.
- Denny, M. W. and Gaylord, B. (2010). Marine ecomechanics. *Ann. Rev. Mar. Sci.* **2**, 89-114.
- Denny, M. W. and Harley, C. D. G. (2006). Hot limpets: predicting body temperature in a conduction-mediated thermal system. *J. Exp. Biol.* **209**, 2409-2419.
- Denny, M. and Helmuth, B. (2009). Confronting the physiological bottleneck: a challenge from ecomechanics. *Integr. Comp. Biol.* **49**, 197-201.
- Dubinsky, Z. and Stambler, N. (2011). *Coral Reefs: An Ecosystem in Transition: An Ecosystem in Transition*. Dordrecht: Springer.
- Edmunds, P. (2005). Effect of elevated temperature on aerobic respiration of coral recruits. *Mar. Biol.* **146**, 655-663.
- Finelli, C., Helmuth, B., Pentcheff, N. and Wethey, D. (2006). Water flow influences oxygen transport and photosynthetic efficiency in corals. *Coral Reefs* **25**, 47-57.
- Finelli, C. M., Helmuth, B. S., Pentcheff, N. D. and Wethey, D. S. (2007). Intracolony variability in photosynthesis by corals is affected by water flow: role of oxygen flux. *Mar. Ecol. Prog. Ser.* **349**, 103-110.
- Fr chet, M., Butman, C. A. and Geyer, W. R. (1989). The importance of boundary-layer flows in supplying phytoplankton to the benthic suspension feeder, *Mytilus edulis* L. *Limnol. Oceanogr.* **34**, 19-36.
- Frederich, M. and P rtner, H. O. (2000). Oxygen limitation of thermal tolerance defined by cardiac and ventilatory performance in spider crab, *Maja squinado*. *Am. J. Physiol.* **279**, R1531-R1538.
- Gaston, K. (2009). Geographic range limits of species. *Proc. R. Soc. B* **276**, 1391-1393.
- Geller, J., Sotka, E., Kado, R., Palumbi, S. and Schwindt, E. (2008). Sources of invasions of a northeastern Pacific acorn barnacle, *Balanus glandula*, in Japan and Argentina. *Mar. Ecol. Prog. Ser.* **358**, 211-218.
- Gerard, V. (1982). *In situ* rates of nitrate uptake by giant kelp, *Macrocystis pyrifera* (L.) C. Agardh: tissue differences, environmental effects, and predictions of nitrogen-limited growth. *J. Exp. Mar. Biol. Ecol.* **62**, 211-224.
- Glazer, B., Marsh, A., Stierhoff, K. and Luther, G., III (2004). The dynamic response of optical oxygen sensors and voltammetric electrodes to temporal changes in dissolved oxygen concentrations. *Anal. Chim. Acta* **518**, 93-100.
- Greenaway, P., Morris, S., McMahon, B., Farrelly, C. and Gallagher, K. (1996). Air breathing by the purple shore crab, *Hemigrapsus nudus* (Dana). I. morphology, behaviour, and respiratory gas exchange. *Physiol. Zool.* **69**, 785-805.
- Helmuth, B. S. (1998). Intertidal mussel microclimates: predicting the body temperature of a sessile invertebrate. *Ecol. Monogr.* **68**, 51-74.
- Hochachka, P. and Somero, G. N. (2002). *Biochemical Adaptation: Mechanism and Process in Physiological Evolution*. Oxford: Oxford University Press.
- Huey, R. B. and Kingsolver, J. G. (1989). Evolution of thermal sensitivity of ectotherm performance. *Trends Ecol. Evol.* **4**, 131-135.
- Huey, R. and Stevenson, R. (1979). Integrating thermal physiology and ecology of ectotherms: a discussion of approaches. *Am. Zool.* **19**, 357-366.
- Hurd, C., Harrison, P. and Druel, L. (1996). Effect of seawater velocity on inorganic nitrogen uptake by morphologically distinct forms of *Macrocystis integrifolia* from wave-sheltered and exposed sites. *Mar. Biol.* **126**, 205-214.
- Jansen, J. M., Hummel, H. and Bonga, S. W. (2009). The respiratory capacity of marine mussels (*Mytilus galloprovincialis*) in relation to the high temperature threshold. *Comp. Biochem. Physiol.* **153A**, 399-402.
- Kearney, M., Shine, R. and Porter, W. P. (2009). The potential for behavioral thermoregulation to buffer 'cold-blooded' animals against climate warming. *Proc. Natl. Acad. Sci. USA* **106**, 3835-3840.
- Kemmer, G. and Keller, S. (2010). Nonlinear least-squares data fitting in Excel spreadsheets. *Nat. Protoc.* **5**, 267-281.
- Koch, E. W., Ackerman, J. D., Verduin, J. and van Keulen, M. (2006). Fluid dynamics in seagrass ecology – from molecules to ecosystems. In *Seagrasses: Biology, Ecology and Conservation* (eds. A. W. Larkum, R. J. Orth and C. M. Duarte), pp. 193-225. Netherlands: Springer.
- Koulish, S. (1981). Ultrastructure of the epidermis and cuticle during the moult-intermoult cycle in two species of adult barnacles. *J. Exp. Mar. Biol. Ecol.* **49**, 121-149.
- Krogh, A. (1919). The rate of diffusion of gases through animal tissues, with some remarks on the coefficient of invasion. *J. Physiol.* **52**, 391-408.
- K hl, M., Cohen, Y., Dalsgaard, T., Jorgensen, B. and Revsbech, N. (1995). Microenvironment and photosynthesis of zooxanthellae in scleractinian corals studied with microensors for O<sub>2</sub>, pH and light. *Mar. Ecol. Prog. Ser.* **117**, 159-172.
- Leonard, G., Levine, J., Schmidt, P. and Bertness, M. (1998). Flow-driven variation in intertidal community structure in a Maine estuary. *Ecology* **79**, 1395-1411.
- Levitus, S., Antonov, J., Boyer, T. and Stephens, C. (2000). Warming of the world ocean. *Science* **287**, 2225-2229.
- Marchinko, K. B. (2003). Dramatic phenotypic plasticity in barnacle legs (*Balanus glandula* Darwin): magnitude, age dependence, and speed of response. *Evolution* **57**, 1281-1290.
- Marchinko, K. B. (2007). Feeding behavior reveals the adaptive nature of plasticity in barnacle feeding limbs. *Biol. Bull.* **213**, 12-15.
- Marshall, D. J., Dong, Y. W., McQuaid, C. D. and Williams, G. A. (2011). Thermal adaptation in the intertidal snail *Echinolittorina malaccana* contradicts current theory by revealing the crucial roles of resting metabolism. *J. Exp. Biol.* **214**, 3649-3657.
- Mass, T., Genin, A., Shavit, U., Grinstein, M. and Tchernov, D. (2010). Flow enhances photosynthesis in marine benthic autotrophs by increasing the efflux of oxygen from the organism to the water. *Proc. Natl. Acad. Sci. USA* **107**, 2527-2531.
- Matoo, O. B., Ivanina, A. V., Ullstad, C., Beniash, E. and Sokolova, I. M. (2013). Interactive effects of elevated temperature and CO<sub>2</sub> levels on metabolism and oxidative stress in two common marine bivalves (*Crassostrea virginica* and *Mercenaria mercenaria*). *Comp. Biochem. Physiol.* **164A**, 545-553.
- McMahon, R. F. and Russell-Hunter, W. D. (1977). Temperature relations of aerial and aquatic respiration in six littoral snails in relation to their vertical zonation. *Biol. Bull.* **152**, 182-198.
- Meehl, G. A., Arblaster, J. M., Fasullo, J. T., Hu, A. and Trenberth, K. E. (2011). Model-based evidence of deep-ocean heat uptake during surface-temperature hiatus periods. *Nature Climate Change* **1**, 360-364.
- Miller, L. (2007). Feeding in extreme flows: behavior compensates for mechanical constraints in barnacle cirri. *Mar. Ecol. Prog. Ser.* **349**, 227-234.
- Moran, A. L. and Woods, H. A. (2010). Limits to diffusive O<sub>2</sub> transport: flow, form, and function in nudibranch egg masses from temperate and polar regions. *PLoS ONE* **5**, e12113.
- Neufeld, C. J. and Palmer, A. R. (2008). Precisely proportioned: intertidal barnacles alter penis form to suit coastal wave action. *Proc. Biol. Sci.* **275**, 1081-1087.
- Newell, R. and Northcroft, H. (1965). The relationship between cirral activity and oxygen uptake in *Balanus balanoides*. *J. Mar. Biol. Assoc. UK* **45**, 387-403.
- Nishihara, G. and Ackerman, J. (2006). The effect of hydrodynamics on the mass transfer of dissolved inorganic carbon to the freshwater macrophyte *Vallisneria spiralis*. *Limnol. Oceanogr.* **51**, 2734-2745.
- Nishihara, G. and Ackerman, J. (2009). Diffusive boundary layers do not limit the photosynthesis of the aquatic macrophyte, *Vallisneria spiralis*, at moderate flows and saturating light levels. *Limnol. Oceanogr.* **54**, 1874-1882.
- O'Donnell, M. (2008). Reduction of wave forces within bare patches in mussel beds. *Mar. Ecol. Prog. Ser.* **362**, 157-167.
- Patterson, M. R. and Sebens, K. P. (1989). Forced convection modulates gas exchange in cnidarians. *Proc. Natl. Acad. Sci. USA* **86**, 8833-8836.
- Patterson, M., Sebens, K. and Olson, R. (1991). *In situ* measurements of flow effects on primary production and dark respiration in reef corals. *Limnol. Oceanogr.* **36**, 936-948.
- P rtner, H. O. and Knust, R. (2007). Climate change affects marine fishes through the oxygen limitation of thermal tolerance. *Science* **315**, 95-97.
- Ritz, D. A. and Foster, B. A. (1968). Comparison of the temperature responses of barnacles from Britain, South Africa and New Zealand, with special reference to temperature acclimation in *Elminius modestus*. *J. Mar. Biol. Assoc. UK* **48**, 545-559.
- Salomon, M. and Buchholz, F. (2000). Effects of temperature on the respiration rates and the kinetics of citrate synthase in two species of *Idotea* (Isopoda, Crustacea). *Comp. Biochem. Physiol.* **125B**, 71-81.
- Sanford, L. and Crawford, S. (2000). Mass transfer versus kinetic control of uptake across solid-water boundaries. *Limnol. Oceanogr.* **45**, 1180-1186.
- Schlichting, H., Gersten, K. and Gersten, K. (2000). *Boundary-Layer Theory*. Berlin: Springer.
- Sebens, K., Witting, J. and Helmuth, B. (1997). Effects of water flow and branch spacing on particle capture by the reef coral *Madracis mirabilis* (Duchassaing and Michelotti). *J. Exp. Mar. Biol. Ecol.* **211**, 1-28.
- Seebacher, F. and Franklin, C. E. (2012). Determining environmental causes of biological effects: the need for a mechanistic physiological dimension in conservation biology. *Philos. Trans. R. Soc. B* **367**, 1607-1614.
- Seibel, B. A. and Childress, J. J. (2013). The real limits to marine life: a further critique of the respiration index. *Biogeosciences* **10**, 2815-2819.
- Sharma, K. R. (2007). *Principles of Mass Transfer*. India: PHI Learning Private Ltd.
- Shashar, N., Cohen, Y. and Loya, Y. (1993). Extreme diel fluctuations of oxygen in diffusive boundary layers surrounding stony corals. *Biol. Bull.* **185**, 455-461.



- Shelford, V. (1911). Physiological animal geography. *J. Morphol.* **22**, 551-618.
- Siikavuopio, S., Mortensen, A. and Christiansen, J. (2008). Effects of body weight and temperature on feed intake, gonad growth and oxygen consumption in green sea urchin, *Strongylocentrotus droebachiensis*. *Aquaculture* **281**, 77-82.
- Somero, G. N. (1969). Enzymic mechanisms of temperature compensation: immediate and evolutionary effects of temperature on enzymes of aquatic poikilotherms. *Am. Nat.* **103**, 517-530.
- Southward, E. C. (1963). Haemoglobin in barnacles. *Nature* **200**, 798-799.
- Southward, A., Hawkins, S. and Burrows, M. (1995). Seventy years' observations of changes in distribution and abundance of zooplankton and intertidal organisms in the western English Channel in relation to rising sea temperature. *J. Therm. Biol.* **20**, 127-155.
- Stevens, C. and Hurd, C. (1997). Boundary-layers around bladed aquatic macrophytes. *Hydrobiologia* **346**, 119-128.
- Stewart, H. and Carpenter, R. (2003). The effects of morphology and water flow on photosynthesis of marine macroalgae. *Ecology* **84**, 2999-3012.
- Thomas, F. and Atkinson, M. (1997). Ammonium uptake by coral reefs: effects of water velocity and surface roughness on mass transfer. *Limnol. Oceanogr.* **42**, 81-88.
- Titus, J. and Adams, M. (1979). Coexistence and the comparative light relations of the submersed macrophytes *Myriophyllum spicatum* L. and *Vallisneria spiralis* L. *Oecologia* **40**, 273-286.
- Underwood, A., Denley, E. and Moran, M. (1983). Experimental analyses of the structure and dynamics of mid-shore rocky intertidal communities in New South Wales. *Oecologia* **56**, 202-219.
- Waite, M. E. and Walker, G. (1986). Haemolymph pressure in certain cirripedes. *J. Exp. Mar. Biol. Ecol.* **98**, 215-230.
- Waite, M. E. and Walker, G. (1988). An investigation aimed at establishing the presence or absence of respiratory (Crustacea: Cirripedia). *Comp. Biochem. Physiol.* **91A**, 849-853.
- Wetthey, D. (1983). Geographic limits and local zonation: the barnacles *Semibalanus (balanus)* and *Cithamalus* in New England. *Biol. Bull.* **165**, 330-341.
- Widdows, J. (1973). The effects of temperature on the metabolism and activity of *Mytilus edulis*. *Netherlands J. Sea Res.* **7**, 387-398.
- Wu, R. and Levings, C. (1978). An energy budget for individual barnacles (*Balanus glandula*). *Mar. Biol.* **45**, 225-235.
- Zar, J. (1999). *Biostatistical Analysis*. Upper Saddle River, NJ: Prentice Hall.