

RESEARCH ARTICLE

The effect of vasopressin 1b receptor (V1bR) blockade on HPA axis activity in rats exposed to acute heat stress

Nebojsa Jasnica*, Jelena Djordjevic, Predrag Vujovic, Iva Latic, Sinisa Djurasevic and Gordana Cvijic
University of Belgrade, Faculty of Biology, Institute for Physiology and Biochemistry, Studentski trg 3, 11000 Belgrade, Serbia

*Author for correspondence (jasnicn@bio.bg.ac.rs)

SUMMARY

Thermal stressors such as low and high ambient temperature elicit an abundance of neuroendocrine responses including activation of the hypothalamo-pituitary-adrenal (HPA) axis and arginine vasopressin (AVP) release. The exposure to heat is a particularly interesting model for studying AVP action because this kind of stressor represents not only an unpleasant experience but also a threat to osmotic homeostasis. As AVP has long been recognized as a hormone involved in the modulation of HPA axis activity, the aim of this study was to elucidate the role of AVP in acutely heat-exposed rats using Nelivaptan, a selective vasopressin 1b receptor (V1bR) antagonist. Rats were exposed to high ambient temperature (38°C) for 60 min. The circulating hormones were determined by ELISA or chemiluminescence, and intrapituitary adrenocorticotrophic hormone (ACTH) and V1bR level were determined by western blot. The results obtained show that V1bR blockade negatively affected the increase in blood ACTH caused by heat exposure. This treatment alone, or in combination with Nelivaptan, decreased intrapituitary V1bR levels while circulating AVP concentration was increased under the same conditions. Furthermore, a strong correlation was observed between blood ACTH and corticosterone concentration. In conclusion, our results directly confirm the positive role of AVP in the regulation of ACTH secretion from the pituitary in animals exposed to heat. Moreover, the results suggest that AVP from the general circulation influences pituitary V1bR.

Key words: SSR149415, adrenocorticotrophic hormone, arginine vasopressin, corticosterone, hypothalamo-pituitary-adrenal.

Received 9 November 2012; Accepted 6 March 2013

INTRODUCTION

The hormonal response to a stressor has been considered as a mechanism to maintain homeostasis after an unpleasant physical or psychological experience. Previous results have revealed that thermal stressors, such as low or high ambient temperature, classified as physical stressors (Kvetnansky et al., 2009), elicit an abundance of neuroendocrine responses including activation of the hypothalamo-pituitary-adrenal (HPA) axis and arginine vasopressin (AVP) release (Aguilera, 1994; Featherby and Lawrence, 2004; Jasnica et al., 2010; Koko et al., 2006; Perčinić-Popovska et al., 2011). It was shown that several brain nuclei are involved in the integration and triggering of this response, with hypothalamic centers playing the pivotal role (Baffi and Palkovits, 2000; Days et al., 2001; Herman et al., 2005). The beginning of the cascade of events, leading to HPA axis activation, may lie in the brainstem catecholaminergic nuclei or limbic brain structures, depending on the nature of the stressor (Herman and Cullinan, 1997). Although the corticotropin-releasing hormone (CRH) is considered to be the major regulator of corticotroph activity, it is now accepted that the next step in triggering the HPA axis response is the secretion of not only CRH but also AVP. They further act in synergy to stimulate adrenocorticotrophic hormone (ACTH) release (Aguilera, 1994; Aguilera and Rabadan-Diehl, 2000; Donald and Wittert, 1994). However, the pattern of CRH, AVP and ACTH secretion varies with the type and duration of the stressor (Donald and Wittert, 1994).

In the mammalian brain, AVP is primarily synthesized within the magnocellular regions of the hypothalamus [the supraoptic nucleus and magnocellular neurons of the paraventricular nucleus (mPVN)]

and also within the parvocellular neurons of the PVN (pPVN) (Roberts et al., 2011). According to Aguilera and Rabadan-Diehl (Aguilera and Rabadan-Diehl, 2000), AVP expression and secretion from the pPVN may be independent of the osmotic status, being increased during stress and involved in the regulation of HPA axis activity. In contrast, data regarding AVP of magnocellular origins are still controversial. While some authors consider that magnocellular AVP is responsible exclusively for water conservation and/or blood pressure regulation (Stricker and Sved, 2002), others believe that this AVP may also act as secretagogue for ACTH, reaching the anterior pituitary via several vascular pathways (Engelmann et al., 2004). Three G protein-coupled receptors, which specifically recognize AVP, have been described and named V1a, V1b and V2, with V1b (also called V3) located mainly on the corticotroph surface and involved in ACTH secretion (Hernando et al., 2001; Maybauer et al., 2008; Thibonnier et al., 1997). In contrast, V2 receptors are involved in osmotic homeostasis maintenance, while the cardiovascular effects of AVP are mediated through the activation of V1a receptors (Maybauer et al., 2008; Warne et al., 2002). It seems that stress regulates pituitary V1b receptor expression, increasing the corticotropin-releasing activity of AVP (de Goeij et al., 1992; Rabadan-Diehl et al., 1995). Because of a lack of selective V1b receptor ligands (agonists/antagonists), the V1b receptor is still poorly characterized and the precise effects of AVP via central and peripheral V1b receptor activation remain to be elucidated. Given that animals lacking V1b receptors display behavioral alterations, including reduced aggression and social memory (Hernando et al., 2001; Lolait et al., 2000), Nelivaptan (code-named SSR149415) was developed as the first selective, non-peptide

and orally applicable V1b receptor antagonist with anxiolytic-like properties. The drug entered clinical trial for anxiety and depression treatment (Serradeil-Le Gal et al., 2005), but in July 2008, Sanofi-Aventis announced that further development of this drug was halted (Kirchhoff et al., 2009). Still, Nelivaptan remains available for conducting experiments on animals as a potent and highly selective V1b receptor antagonist (Serradeil-Le Gal et al., 2002).

That said, and owing to the lack of data regarding the control of the HPA axis activation under the influence of heat, our goal was to examine the role of AVP in HPA axis activity in acutely (1 h) heat-exposed rats using Nelivaptan. Heat stress is a particularly interesting model for studying AVP as this kind of stress represents not only an unpleasant experience but also a threat to osmotic homeostasis.

MATERIALS AND METHODS

Animal handling and treatments were carried out in accordance with the Serbian animal protection law and approved by the Ethical Committee of the University of Belgrade Faculty of Biology (approval no. EK-BF-2010/011). The work described in this article was carried out in accordance with the EU Directive 2010/63/EU for animal experiments, and the uniform requirements for manuscripts submitted to biomedical journals.

Experimental design

Male Wistar rats, *Rattus norvegicus* (Berkenhout 1769), weighing 220 ± 20 g were used for the experiments. They were caged in groups of two for at least 1 week before the procedures were conducted. The animals were acclimated to $22 \pm 1^\circ\text{C}$, synchronized to a 12 h:12 h light:dark regime with lights on at 06:00 h and off at 18:00 h, with free access to commercial rat food (Veterinary Institute, Subotica, Serbia) and tapwater. The rats were randomly divided into five groups (control, vehicle, Nelivaptan, heat, Nelivaptan + heat), each consisting of six animals. In order to avoid day–night variations in the concentrations of the measured hormones, all experiments were performed between 08:00 h and 10:00 h. While the control rats were left undisturbed in the housing facility, rats exposed to heat were transferred into a temperature chamber at $+38^\circ\text{C}$ (Sutjeska, Belgrade, Serbia) for a period of 1 h. The animals from the vehicle and Nelivaptan groups received intraperitoneal (i.p.) injection of the vehicle (1 ml kg^{-1} , 5% DMSO, 95% saline) or Nelivaptan dissolved in the vehicle (1 ml kg^{-1} ; stock concentration 5 mg ml^{-1}), respectively. The group of rats in the Nelivaptan + heat group received i.p. injection of Nelivaptan (1 ml kg^{-1} ; stock concentration 5 mg ml^{-1}), 30 min before being exposed to heat ($+38^\circ\text{C}$) for 1 h. The decision regarding Nelivaptan dosage and its administration time was made on the basis of previously published data (Ramos et al., 2006; Serradeil-Le Gal et al., 2002). Before and immediately after the treatment, body mass and rectal temperature were measured.

The animals were decapitated with a guillotine (Harvard-Apparatus, Holliston, MA, USA) without anesthesia immediately after the last stress exposure (heat, Nelivaptan + heat), or 90 min after i.p. injection was received (vehicle, Nelivaptan). The heads were plunged into the iced water and the blood, collected from the trunk, was divided into two sets of tubes, with EDTA added to obtain plasma.

Biochemical methods

Serum and plasma were frozen at -80°C until ACTH, AVP and corticosterone (CORT) determination. The plasma ACTH concentration was determined by a chemiluminescence method using an IMMULITE automatic analyzer (DPC, Los Angeles, CA, USA), while serum AVP concentration was measured by

commercially available ELISA test (Peninsula Laboratories, LLC, San Carlos, CA, USA). The results were presented as pg ACTH ml^{-1} plasma or pg AVP ml^{-1} serum. Serum corticosterone levels were determined by EIA kit (Immunodiagnostic Systems, Boldon, UK) and the values were expressed as ng CORT ml^{-1} serum.

Western blot analysis

The pituitary glands were promptly dissected, weighed and homogenized in protein isolation buffer containing 1.5 mol l^{-1} NaCl, 10% Triton X-100, 0.5 mol l^{-1} Tris-HCl (pH 7.5), 10% SDS and a cocktail of protease inhibitors (Roche, Basel, Switzerland). After homogenization, the samples were sonicated (3×10 s) and centrifuged for 25 min at 14,000 r.p.m. The total protein concentration was determined using the method described by Lowry and co-workers (Lowry et al., 1951). The intrapituitary ACTH and V1bR concentration was determined by western blot analysis (Burnette, 1981). The samples containing 2 mg ml^{-1} of total protein were added to an equal volume of Laemmli buffer with 2-mercaptoethanol (200:5, v.v.). After denaturation by boiling at 100°C for 5 min, the samples were separated on a 20% (for ACTH) or 12% (for V1bR) polyacrilamide gel (120 V, Criterion Cell, Bio-Rad, Hercules, CA, USA) and electrotransferred (overnight, 20 mA per gel, Criterion blotter, Bio-Rad) onto 0.45 mm polyvinylidene difluoride (PVDF) membranes. Subsequent to the transfer of proteins, membranes were blocked for 3 h in 5% non-fat dry milk powder (Santa Cruz Biotechnology, Heidelberg, Germany) in Tris-buffered saline containing 0.1% Tween 20 (TBST). After that, the blots were incubated with primary antibody (ACTH, rabbit monoclonal, 1:4000, kindly provided by Dr A. F. Parlow, National Institute of Diabetes and Digestive and Kidney Diseases, National Hormone and Peptide Program, Torrance, CA, USA; V1bR, rabbit polyclonal, 1:1000, sc-30026, Santa Cruz Biotechnology), and thoroughly washed in TBST before a 1 h incubation with horseradish peroxidase-conjugated secondary goat anti-rabbit polyclonal antibody (1:5000, ab6721 Abcam, Cambridge, UK). After washing in TBST, the membranes were incubated with the enhanced chemiluminescence (ECL) plus detection system (Amersham, Bucks, UK) for 5 min. Excess ECL plus solution was then removed, and the immunoreactive bands were detected in the dark chamber. The intensity of signals was evaluated by the Image Quant program (Molecular Dynamics, Amersham Biosciences) and calculated as the number of arbitrary units (a.u.) mg^{-1} of total protein. Those results were then recalculated and the specific protein content of all groups was expressed relative to the control group value on the graphs.

Statistical analysis

Data were statistically evaluated by two-way analysis of variance (ANOVA), using GraphPad Prism (Version 4.03) software. A Bonferroni multiple comparison test was performed when ANOVA was significant. The values were presented as the means \pm s.e.m. of six animals and the level of significance was set at $P < 0.05$.

RESULTS

Table 1 reveals that acute exposure to heat ($+38^\circ\text{C}$ for 1 h) induced a significant increase in rectal temperature, regardless of previous administration of the V1bR antagonist Nelivaptan. However, when animals were not exposed to high ambient temperature, their rectal temperature remained unchanged.

As far as the body mass is concerned, it can be seen (Fig. 1) that exposure to high ambient temperature caused a significant decrease, regardless of pretreatment with Nelivaptan (compare heat and Nelivaptan + heat with control).

Table 1. Rectal temperature (°C) before and after treatment

	Vehicle	Nelivaptan	Heat	Nelivaptan + heat
Before exposure	37.0±0.0	37.3±0.2	37.2±0.1	37.0±0.2
After exposure	36.9±0.1	37.1±0.1	39.8±0.1*	39.8±0.1*

Animals were treated with vehicle or Nelivaptan, exposed to heat or treated with Nelivaptan prior to heat exposure.

An asterisk indicates a significant difference in rectal temperatures measured before and after heat exposure for the same group of animals. Values are means ± s.e.m. of six animals.

Fig. 2 shows that all the performed treatments led to a significant depletion of ACTH from the pituitary gland, as compared with the intact controls. Additionally, it can be seen that heat exposure alone had the strongest effect. In contrast, in animals pretreated with Nelivaptan and then exposed to heat, ACTH content of the pituitary gland was higher than that in animals exposed to heat alone.

Heat stress caused a significant increase in blood ACTH concentration (Fig. 3) in comparison to the control values. In contrast, vehicle or Nelivaptan application did not change ACTH level. When animals were pretreated with Nelivaptan, heat stress led to an increase in the circulating ACTH level, but this was less prominent than that in animals exposed to heat only.

Fig. 4 reveals that changes occurring in the circulating CORT concentrations were mainly similar to those of the circulating ACTH. Namely, heat stress also caused a significant increase in circulatory CORT concentrations compared with the control, while vehicle or Nelivaptan did not affect its circulatory level. Although heat stress caused an increase in circulatory CORT concentration in animals pretreated with Nelivaptan, its level was not statistically different from that obtained for animals exposed to heat stress alone; however, in the Nelivaptan-pretreated group of animals, CORT levels tended to decrease compared with the heat stress group.

Regarding the pituitary V1bR (Fig. 5), all treatments, except for vehicle administration, caused levels to decrease (compare heat with control, Nelivaptan with vehicle, and Nelivaptan + heat with heat alone).

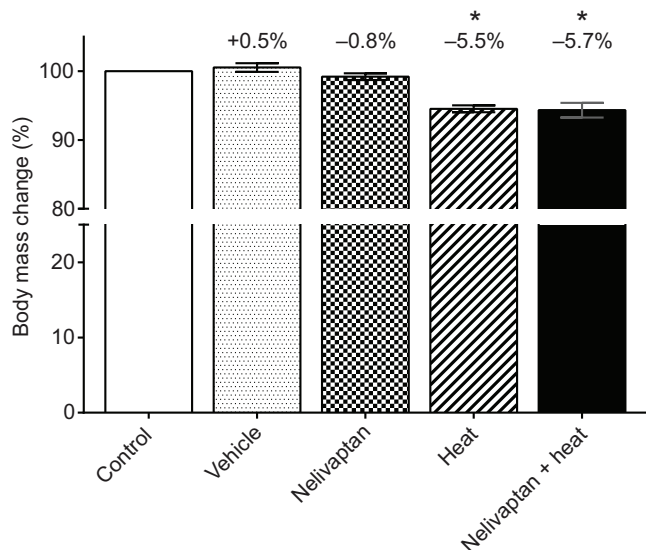

Fig. 1. The body mass change (expressed as percentage of control, measured before the experimental procedure) of animals treated with vehicle or Nelivaptan, exposed to heat or treated with Nelivaptan prior to heat exposure. An asterisk indicates a significant difference between the control and treated group of animals. Values are means ± s.e.m. of six animals.

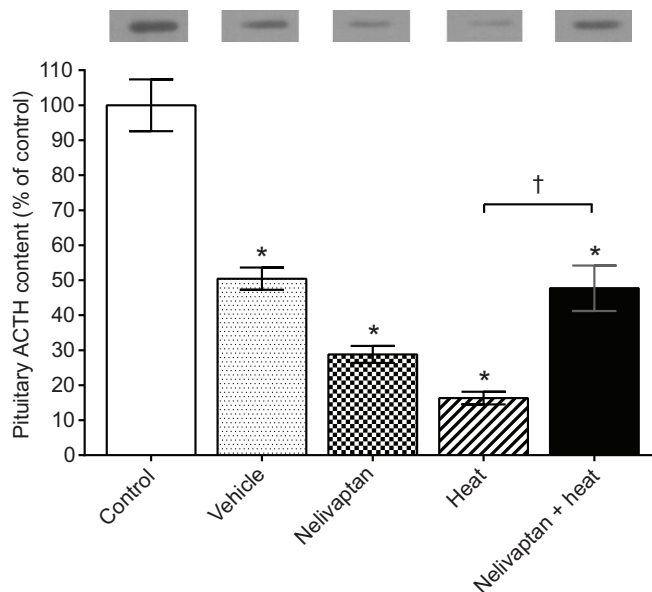

Fig. 2. The pituitary adrenocorticotrophic hormone (ACTH) content (relative to control group) in control animals, and animals treated with vehicle or Nelivaptan, exposed to heat or treated with Nelivaptan prior to heat exposure. An asterisk indicates a significant difference between the control and treated group of animals, while a dagger indicates a significant difference between treated groups. Values are means ± s.e.m. of six animals. The results of the western blot for ACTH are presented above each bar.

Fig. 6 shows that under the influence of heat, Nelivaptan, or heat + Nelivaptan combined, AVP blood concentration was increased compared with control. In contrast, vehicle administration did not affect the circulatory AVP concentration.

DISCUSSION

In the present study, we used the V1bR antagonist Nelivaptan in order to reveal the influence of AVP on HPA axis activity in animals exposed to high ambient temperature. The results obtained show the significant correlation between V1bR activity and ACTH secretion. Both our previously published results and our present ones suggest that AVP from the general circulation affected hypothalamic V1bR.

In our present study, rectal temperature increased as expected when animals were exposed to high ambient temperature, supporting the previous results that 1 h exposure to the chosen temperature (+38°C) represents a strong enough stressor to cause an imbalance of thermal homeostasis (Djordjević et al., 2003). Moreover, the decrease in body mass of animals exposed to heat (Fig. 1) implies that these animals lost a considerable amount of water. It is well known that in conditions of elevated ambient temperature, rats must activate all mechanisms, including characteristic behavior to prevent the elevation of body temperature, to maintain or regain thermal homeostasis. Thus, intense salivation was accompanied by excessive body licking and saliva spreading, presumably to enhance evaporation, and thus induce heat loss and lower the body temperature. As a result of coping with increased ambient temperature and the consequent water loss, the body mass and the rectal temperature changed in the manner described above.

On the basis of the aforementioned results and those concerning the blood vasopressin concentration (Fig. 6), it can be concluded that water loss led to the osmotic imbalance, which triggered

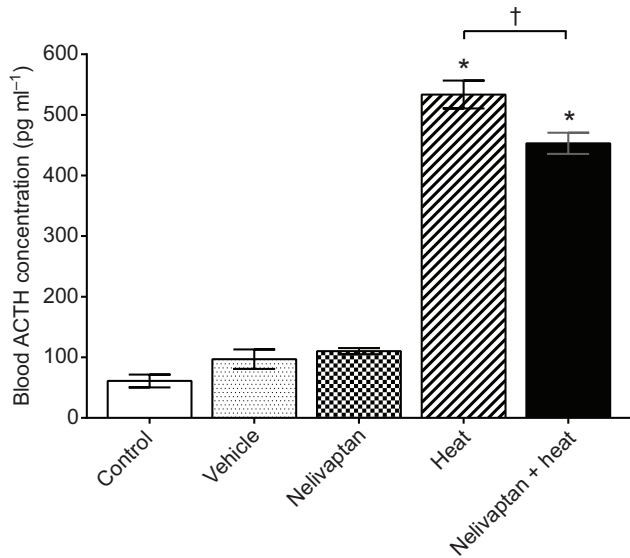

Fig. 3. Blood ACTH concentration in control animals, and animals treated with vehicle or Nelivaptan, exposed to heat or treated with Nelivaptan prior to heat exposure. An asterisk indicates a significant difference between the control and treated group of animals, while a dagger indicates a significant difference between treated groups. Values are means \pm s.e.m. of six animals.

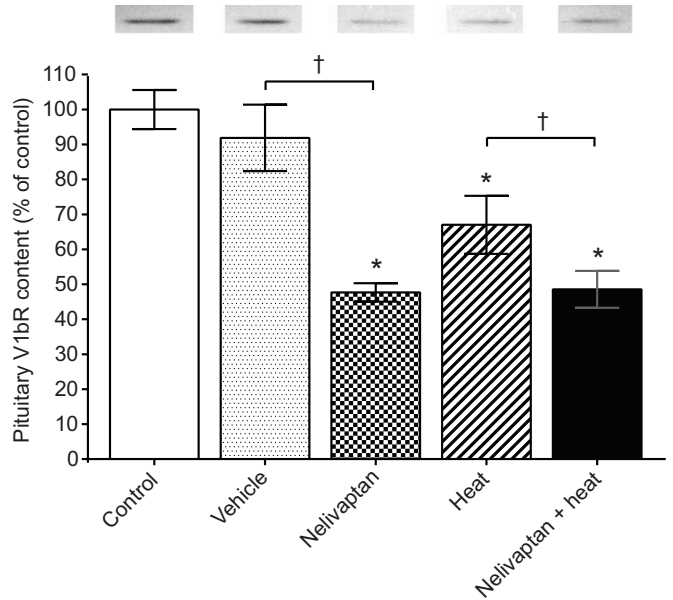

Fig. 5. The pituitary vasopressin 1b receptor (V1bR) content (relative to control) in animals treated with vehicle or Nelivaptan, exposed to heat or treated with Nelivaptan prior to heat exposure. An asterisk indicates a significant difference between the control and treated group of animals, while a dagger indicates a significant difference between treated groups. Values are means \pm s.e.m. of six animals. The results of the western blot are presented above each bar.

vasopressin secretion in order to re-establish homeostasis (Fig. 7). However, it still does not explain the elevated blood AVP concentration in animals treated with Nelivaptan only. Given that Nelivaptan blocks the action of AVP through activation of V1b receptors, mostly present in the pituitary and brain, it is reasonable to assume that the obtained increase in blood AVP concentration might result from the lack of its physiological action. In contrast to previously obtained results regarding the ability of circulating AVP to act on V1bR (Engelmann et al., 2004; Plotsky, 1991), our present results, and those published before (Jasnic et al., 2010), indicate

that AVP, secreted into the general circulation, reaches the V1bR in concentrations sufficient for physiological action (Fig. 7).

It is also noteworthy that we have observed a correlation between the elevated blood AVP concentration (Fig. 6) and decreased V1bR amount in the pituitary gland (Fig. 5). It should be mentioned that out of the four AVP/oxytocin (OT) receptor subtypes cloned so far, the V1bR is still poorly described because of its limited and sparse

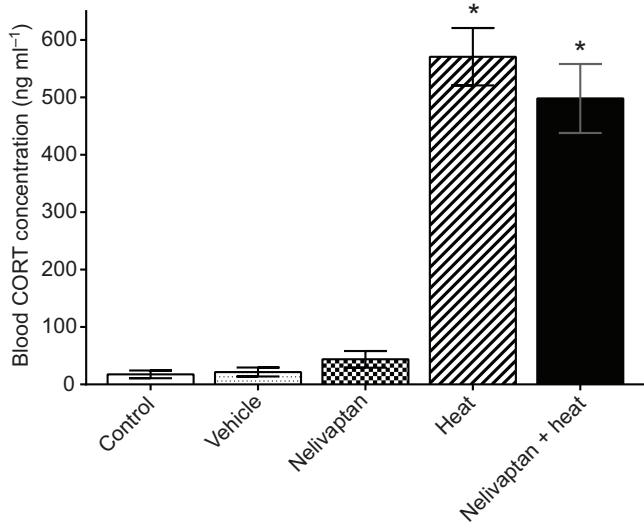

Fig. 4. Blood corticosterone (CORT) concentration in control animals, and animals treated with vehicle or Nelivaptan, exposed to heat or treated with Nelivaptan prior to heat exposure. An asterisk indicates a significant difference between the control and treated group of animals. Values are means \pm s.e.m. of six animals.

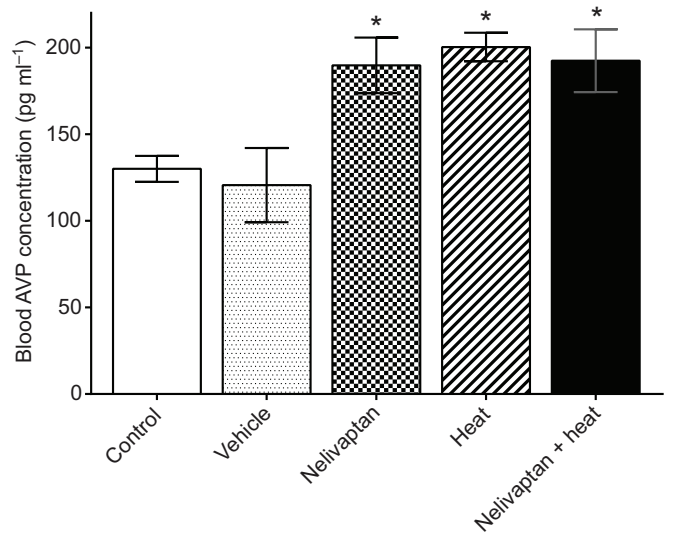

Fig. 6. Blood arginine vasopressin (AVP) concentration in control animals, and animals treated with vehicle or Nelivaptan, exposed to heat or treated with Nelivaptan prior to heat exposure. An asterisk indicates a significant difference between the control and treated group of animals. Values are means \pm s.e.m. of six animals.

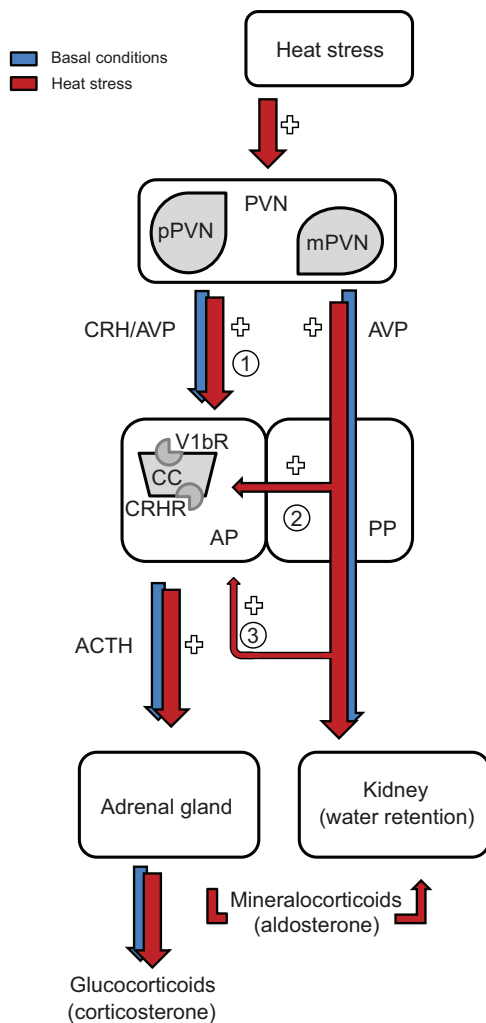

Fig. 7. The impact of heat stress on hypothalamo-pituitary-adrenal (HPA) axis activity. Magnocellular AVP-producing neurons of the paraventricular nucleus (mPVN) project through the zona interna of the median eminence to the posterior pituitary (PP). At the level of the PP, AVP is stored in axon terminals and secreted into the general blood circulation upon stimulation. This represents the main pathway of AVP action on water retention under both resting and stress conditions. In contrast, there are at least three proposed pathways for AVP to reach the corticotrophs in the anterior pituitary (AP). In the first (1), parvocellular neurons of the PVN (pPVN) project to the zona externa of the median eminence and secrete corticotropin-releasing hormone (CRH) as well as AVP into the long portal vessels. This pathway constitutes the central neuro-endocrine part of the HPA axis, being active under both resting and stress conditions. Reaching the corticotrophs, CRH and AVP synergistically trigger the release of ACTH. In the second (2), during the heat stress, AVP is released from axon terminals in the PP into short portal vessels, which connect the AP and PP. Finally (3), it is proposed that AVP secreted during stress from the PP into the general blood circulation could also reach the corticotrophs. Elevated blood ACTH concentration during heat stress positively affects not only adrenal glucocorticoid but mineralocorticoid production as well. Together with elevated AVP blood concentration, mineralocorticoids additionally help to prevent excessive water loss, given that aldosterone also stimulates water retention. As CRH is identified as the main ACTH secretagogue, V1bR blockade does not abolish but rather attenuates the pituitary ACTH secretion (by about 15%, according to our results).

expression, and because of the lack of a V1bR agonist or antagonist. However, the reason for the observed correlation could be the fact that V1bR belongs to A-type receptors, undergoing dynamic

endocytosis and rapid recycling (30 min) upon agonist stimulation (Serradeil-Le Gal et al., 2007). Other receptors, such as V1aR, β -adrenergic and opiate receptors, also belong to this class, in contrast to V2R, a member of B-type receptors, which is also internalized, but is recycled more slowly (2h) and is mainly degraded in the lysosomal compartment (Bouley et al., 2005). Although Serradeil-Le Gal and co-workers (Serradeil-Le Gal et al., 2007) reported a protective role of Nelivaptan on V1bR internalization, our results did not show this tendency likely due to the different animal model (human/mouse *versus* rat) or methodological approach (*in vitro* *versus* *in vivo*). Additional experiments are needed in order to answer this question.

As Fig. 7 depicts, in terms of physiological function, the pituitary V1bR is mostly involved in the stimulating effect of AVP on ACTH secretion, thus controlling the stress response (Aguilera and Rabadan-Diehl, 2000). For this reason, we measured the ACTH concentration both in the pituitary gland and in the circulation. It was previously shown that, *in vivo*, Nelivaptan interacts with the rat pituitary V1bR, inhibiting the increased ACTH secretion caused by various stimulants (Ramos et al., 2006; Serradeil-Le Gal et al., 2002). However, so far no evidence has been reported on the effect of Nelivaptan on ACTH release in animals exposed to heat stress, a physical stressor accompanied by disturbed osmotic homeostasis. Predictably, the circulating ACTH levels were elevated in animals exposed to heat stress, regardless of the presence of Nelivaptan, while vehicle or Nelivaptan administration did not significantly influence the plasma concentration of this hormone (Fig. 3). At the same time, pituitary ACTH levels decreased compared with the control animals, suggesting that all the treatments applied represent a kind of stressor of different intensity. It is very important to emphasize that the increase in circulating ACTH concentration was significantly attenuated in animals that were pretreated with Nelivaptan before heat exposure compared with those exposed to heat only (Fig. 3). This is direct proof of the influence of AVP on HPA activity in animals exposed to high ambient temperature.

Finally, it can be observed (Fig. 4) that blood CORT concentration corresponded well with that of ACTH, showing a less prominent increase (although insignificant) in animals pretreated with Nelivaptan before exposure to heat in comparison to those exposed to heat only.

In conclusion, our results show a negative correlation between the action of Nelivaptan and ACTH secretion in animals exposed to heat stress, thus directly confirming the role of AVP in the regulation of HPA activity in these animals. Moreover, the results suggest that AVP from the general circulation influences hypothalamic V1bR, given that AVP concentration was increased when V1bRs were blocked.

LIST OF ABBREVIATIONS

ACTH	adrenocorticotrophic hormone
AVP	arginine vasopressin
CORT	corticosterone
CRH	corticotropin-releasing hormone
HPA	hypothalamo-pituitary-adrenal
mPVN	magnocellular neurons of the paraventricular nucleus
Nelivaptan	generic name for V1bR antagonist SSR149415
pPVN	parvocellular neurons of the paraventricular nucleus
V1bR	vasopressin 1b receptor

ACKNOWLEDGEMENTS

We are grateful to Mrs Danka Filipovic for language editing of an earlier version of the manuscript.

AUTHOR CONTRIBUTIONS

As senior investigators, G.C. and J.D. contributed to the concept and design of the present work, and assisted in data interpretation. S.D. provided statistical analyses of data and prepared the figures. N.J., P.V. and I.L. executed all experiments. N.J. prepared the first draft of the manuscript, while all authors listed made equal efforts in revising the article.

COMPETING INTERESTS

No competing interests declared.

FUNDING

This work was supported by the Serbian Ministry of Education, Science and Technological Development [project no. 173023].

REFERENCES

- Aguilera, G. (1994). Regulation of pituitary ACTH secretion during chronic stress. *Front. Neuroendocrinol.* **15**, 321-350.
- Aguilera, G. and Rabadan-Diehl, C. (2000). Vasopressinergic regulation of the hypothalamic-pituitary-adrenal axis: implications for stress adaptation. *Regul. Pept.* **96**, 23-29.
- Baffi, J. S. and Palkovits, M. (2000). Fine topography of brain areas activated by cold stress. A fos immunohistochemical study in rats. *Neuroendocrinology* **72**, 102-113.
- Bouley, R., Lin, H. Y., Raychowdhury, M. K., Marshansky, V., Brown, D. and Ausiello, D. A. (2005). Downregulation of the vasopressin type 2 receptor after vasopressin-induced internalization: involvement of a lysosomal degradation pathway. *Am. J. Physiol. Cell Physiol.* **288**, C1390-C1401.
- Burnette, W. N. (1981). 'Western blotting': electrophoretic transfer of proteins from sodium dodecyl sulfate-polyacrylamide gels to unmodified nitrocellulose and radiographic detection with antibody and radioiodinated protein A. *Anal. Biochem.* **112**, 195-203.
- Dayas, C. V., Buller, K. M., Crane, J. W., Xu, Y. and Day, T. A. (2001). Stressor categorization: acute physical and psychological stressors elicit distinctive recruitment patterns in the amygdala and in medullary noradrenergic cell groups. *Eur. J. Neurosci.* **14**, 1143-1152.
- de Goeij, D. C., Jezova, D. and Tilders, F. J. (1992). Repeated stress enhances vasopressin synthesis in corticotropin releasing factor neurons in the paraventricular nucleus. *Brain Res.* **577**, 165-168.
- Djordjević, J., Cvijić, G. and Davidović, V. (2003). Different activation of ACTH and corticosterone release in response to various stressors in rats. *Physiol. Res.* **52**, 67-72.
- Donald, R. A. and Wittert, G. A. (1994). Stress and corticotropin regulation. *Curr. Opin. Endocrinol. Diabetes* **1**, 93-99.
- Engelmann, M., Landgraf, R. and Wotjak, C. T. (2004). The hypothalamic-neurohypophysial system regulates the hypothalamic-pituitary-adrenal axis under stress: an old concept revisited. *Front. Neuroendocrinol.* **25**, 132-149.
- Featherby, T. and Lawrence, A. J. (2004). Chronic cold stress regulates ascending noradrenergic pathways. *Neuroscience* **127**, 949-960.
- Herman, J. P. and Cullinan, W. E. (1997). Neurocircuitry of stress: central control of the hypothalamo-pituitary-adrenocortical axis. *Trends Neurosci.* **20**, 78-84.
- Herman, J. P., Ostrander, M. M., Mueller, N. K. and Figueiredo, H. (2005). Limbic system mechanisms of stress regulation: hypothalamo-pituitary-adrenocortical axis. *Prog. Neuropsychopharmacol. Biol. Psychiatry* **29**, 1201-1213.
- Hernando, F., Schoots, O., Lolait, S. J. and Burbach, J. P. (2001). Immunohistochemical localization of the vasopressin V1b receptor in the rat brain and pituitary gland: anatomical support for its involvement in the central effects of vasopressin. *Endocrinology* **142**, 1659-1668.
- Jasnic, N., Korac, A., Velickovic, K., Golic, I., Djordjevic, J., Djurasevic, S., Djordjevic, I., Vujovic, P. and Cvijic, G. (2010). The effect of acute heat exposure on rat pituitary corticotroph activation: the role of vasopressin. *Folia Histochem. Cytobiol.* **48**, 507-512.
- Kirchhoff, V. D., Nguyen, H. T., Soczynska, J. K., Woldeyohannes, H. and McIntyre, R. S. (2009). Discontinued psychiatric drugs in 2008. *Expert Opin. Investig. Drugs* **18**, 1431-1443.
- Koko, V., Djordjevic, J., Cvijic, G. and Davidovic, V. (2006). Effect of the acute heat stress on the rat pituitary gland. Morphological and stereological study. *J. Therm. Biol.* **31**, 394-399.
- Kvetnansky, R., Sabban, E. L. and Palkovits, M. (2009). Catecholaminergic systems in stress: structural and molecular genetic approaches. *Physiol. Rev.* **89**, 535-606.
- Lolait, S., O'Carroll, A. M., Shepard, E., Ginns, E. I. and Young, W. S. (2000). Characterization of a vasopressin V1b receptor knockout mouse. *Soc. Neurosci. Abstr.* **26**, 2406.
- Lowry, O. H., Rosebrough, N. J., Farr, A. L. and Randall, R. J. (1951). Protein measurement with the Folin phenol reagent. *J. Biol. Chem.* **193**, 265-275.
- Maybauer, M. O., Maybauer, D. M., Enkhbaatar, P. and Traber, D. L. (2008). Physiology of the vasopressin receptors. *Best Pract. Res. Clin. Anaesthesiol.* **22**, 253-263.
- Perčinić-Popovska, F., Ajdzanovic, V., Dinevska-Kofkarovska, S., Jordanova, M., Trifunovic, S., Sosic-Jurjevic, B. and Milosevic, V. (2011). Morphofunctional characteristics of pituitary adrenocorticotropes in an animal model of heat stress. *J. Med. Biochem.* **30**, 287-292.
- Plotsky, P. M. (1991). Pathways to the secretion of adrenocorticotropin: a view from the portal. *J. Neuroendocrinol.* **3**, 1-9.
- Rabadan-Diehl, C., Lolait, S. J. and Aguilera, G. (1995). Regulation of pituitary vasopressin V1b receptor mRNA during stress in the rat. *J. Neuroendocrinol.* **7**, 903-910.
- Ramos, A. T., Troncone, L. R. and Tufik, S. (2006). Suppression of adrenocorticotrophic hormone secretion by simultaneous antagonism of vasopressin 1b and CRH-1 receptors on three different stress models. *Neuroendocrinology* **84**, 309-316.
- Roberts, E. M., Pope, G. R., Newson, M. J., Lolait, S. J. and O'Carroll, A. M. (2011). The vasopressin V1b receptor modulates plasma corticosterone responses to dehydration-induced stress. *J. Neuroendocrinol.* **23**, 12-19.
- Serradeil-Le Gal, C., Wagnon, J., Simiand, J., Griebel, G., Lacour, C., Guillon, G., Barberis, C., Brossard, G., Soubrié, P., Nisato, D. et al. (2002). Characterization of (2S,4R)-1-[5-chloro-1-[(2,4-dimethoxyphenyl)sulfonyl]-3-(2-methoxy-phenyl)-2-oxo-2,3-dihydro-1H-indol-3-yl]-4-hydroxy-N,N-dimethyl-2-pyrrolidine carboxamide (SSR149415), a selective and orally active vasopressin V1b receptor antagonist. *J. Pharmacol. Exp. Ther.* **300**, 1122-1130.
- Serradeil-Le Gal, C., Wagnon, J., 3rd, Tonnerre, B., Roux, R., Garcia, G., Griebel, G. and Aulombard, A. (2005). An overview of SSR149415, a selective nonpeptide vasopressin V(1b) receptor antagonist for the treatment of stress-related disorders. *CNS Drug Rev.* **11**, 53-68.
- Serradeil-Le Gal, C., Raufaste, D., Derick, S., Blankenstein, J., Allen, J., Pouzet, B., Pascal, M., Wagnon, J. and Ventura, M. A. (2007). Biological characterization of rodent and human vasopressin V1b receptors using SSR-149415, a nonpeptide V1b receptor ligand. *Am. J. Physiol. Regul. Integr. Comp. Physiol.* **293**, R938-R949.
- Stricker, E. M. and Sved, A. F. (2002). Controls of vasopressin secretion and thirst: similarities and dissimilarities in signals. *Physiol. Behav.* **77**, 731-736.
- Thibonnier, M., Preston, J. A., Dulin, N., Wilkins, P. L., Berti-Mattera, L. N. and Mattera, R. (1997). The human V3 pituitary vasopressin receptor: ligand binding profile and density-dependent signaling pathways. *Endocrinology* **138**, 4109-4122.
- Warne, J. M., Harding, K. E. and Balment, R. J. (2002). Neurohypophysial hormones and renal function in fish and mammals. *Comp. Biochem. Physiol.* **132B**, 231-237.